

# 30 – SHIFT-CONTROL MECHANISMS

---

## ABOUT THIS CHAPTER

This chapter is about shift levers and twist-grip shifters. There are separate chapters about the setup of control cables that attach to the shift-control mechanisms (**DERAILLEUR-CABLE SYSTEMS**, page 31-1), but this chapter includes information about installing the inner wire into the shift-control mechanism. There is a separate **REAR DERAILLEURS** chapter (page 32-1) and **FRONT DERAILLEURS** chapter (page 33-1).

## GENERAL INFORMATION

### TERMINOLOGY

**Shift-control mechanism:** A lever or twist grip that the rider uses to control the derailleur operations.

**Shift lever:** A lever that is rotated about a pivot to move the inner wire that operates the derailleur.

**Shifter drum:** A cylinder that the cable wraps around when the shifter is rotated.

**Twist grip:** A cylinder that is part of the hand grip on the handlebar that is rotated around the handlebar to move the inner wire that operates the derailleur.

**Grip Shift:** See *twist grip*.

**Down-tube levers:** Shift-control mechanisms that are mounted on the down tube of the frame.

**Stem shifters:** Shift-control mechanisms that are mounted on the vertical shaft of the stem.

**Bar-end shifters:** Shift-control mechanisms that are mounted in the ends of drop-style handlebars.

**Bar cons:** See *bar-end shifters*.

**Top-mount shifters:** Shift-control mechanisms that are mounted on top of MTB-style handlebars.

**Thumb shifters:** See *top mount shifters*.

**Below-bar shifters:** Shift-control mechanisms that are mounted so that they are reached by using the thumb below the bar on MTB-style handlebars.

**Integral shift/brake levers:** Shift-control mechanisms found on road bikes with which the shift levers are integrated into the brake levers.

**Inner wire:** The wire portions of the shift-control cable.

**Housing:** The outer sheath of the shift-control cable.

**Shift-control cable:** The inner wire and housing that work as a unit to transfer a change at the shift-control mechanism to the derailleur.

**Adjusting barrel:** A hollow bolt that the inner wire passes through, with a socket head that the housing inserts into. The adjusting barrel is screwed in and out of the shift-control mechanism to adjust the relative length of the inner wire.

**Indexed (shifting):** A shifting system in which the shift-control mechanism stops at prescribed increments, rather than anywhere within a prescribed range. When an indexed shift-control mechanism is moved to one of the prescribed positions, the shift is completed automatically.

**Friction (shifting):** A shifting system in which the shift-control mechanism moves to an infinite number of positions within a prescribed range. The shift-control mechanism is moved to wherever the operator chooses to complete the shift. It is not automatic.

**Front derailleur:** The mechanism that moves the chain between gear choices on the crankset.

**Rear derailleur:** The mechanism that moves the chain between gear choices on the rear hub.

### PREREQUISITES

If installing a new shift-control mechanism or replacing an existing one, cable installation and derailleur indexing adjustment will be required. There are no other prerequisites.

### INDICATIONS

#### *Maintenance*

Most of the time, the only maintenance needed by a shift-control mechanism is lubrication. Sometimes they need partial disassembling and cleaning.

#### *Derailleur replacement*

Derailleurs and shift-control mechanisms must be compatible. Sometimes changing a derailleur means that a new shift-control mechanism is needed.

### ***Rear cogset replacement***

Sometimes a cogset will be changed to have more gears. The derailleur may be able to handle the increase, but an indexing shift-control mechanism is almost always set for a specific number of gears.

### ***Symptoms indicating need for cleaning***

Any shifting system is complex, and a symptom may be caused by any of several parts of the system. An indexing lever in need of cleaning will create a symptom of the indexing adjustment being too tight and too loose at the same time. This can also be caused by control-cable problems, dirty or worn-out chain or derailleur, or compatibility problems with the shift-control mechanism, derailleur, chain, and cogset.

### ***Symptoms indicating need for replacement***

The symptom indicating need for replacement is the same as the symptom indicating need for cleaning, except when all the other causes have been eliminated and cleaning has been done, the symptom persists.

Indexing shift-control mechanisms have delicate internal parts that sometimes break. The symptom will be either a lever that will not move, or it moves but the control cable cannot. The same symptom can also be caused by the inner wire being installed wrong. If the inner wire is in correctly, the shift-control mechanism needs to be replaced.

## **TOOL CHOICES**

Installing and removing a shift-control mechanism requires no special tools. As a consequence of installing a shift-control mechanism, a derailleur will need adjustment, but any special tools for this are covered in the **REAR DERAILLEURS** chapter (page 32-5) and **FRONT DERAILLEURS** chapter (page 33-3).

Shimano STI levers (road-bike shift levers that are integrated into the brake levers) require a couple of special tools called the TL-ST01 and TL-ST02 for disassembling the lever.

## **TIME AND DIFFICULTY**

In most cases, installing a shift-control mechanism is a 2–5 minute job of little difficulty. Adjustment of the derailleur is additional. If installing bar-end shifters, taping the bars is additional. If changing between a lever system that is integrated with the brake levers and one that is not, brake-lever installation and brake adjustment would take additional time. For the time and difficulty rating of all these additional factors, see the chapters that pertain to them.

## **COMPLICATIONS**

### ***Compatibility with derailleur***

Shift-control mechanisms must be compatible with the derailleurs they are used with. An indexing shifter moves a fixed amount of cable for each click of the control. This amount of cable motion must be the correct amount to move the derailleur precisely from one gear to the next.

Any table of compatibility is doomed to becoming outdated rapidly. Manufacturer's technical support and literature will always be a better source of information. As a general guideline, different brands of shifters and derailleurs can rarely be matched (except Grip Shift brand, which are made specifically for other brands of derailleurs). Even models within a brand may be incompatible; for example, Shimano Dura-Ace components can't be mixed with other Shimano components.

When in doubt, it is possible to test for whether two components are compatible. In the **REAR DERAILLEURS** chapter is a section called **FUNCTIONAL RANGE OF ADJUSTMENT** (page 32-21) that describes a test that measures shifting performance. If mismatched equipment performs well in this test, it is compatible.

### ***Compatibility with inner wire***

Shape and size of the inner-wire head is important. Some modern shifters have plastic sockets that the inner-wire head seats in. If it is not a good fit, it can jam in place and be very difficult to ever get out. Before using a wire, insert its head backwards into the shifter socket and make sure it slips all the way in and out easily.

Inner-wire diameter is important with indexing shifters. The amount of cable pulled with each click of the shifter is a function of the diameter of the cylinder (shifter drum) that the cable is wrapping around and the inner-wire diameter. Until 1995, all indexing levers used a 1.2mm inner wire except Shimano Dura-Ace (1.6mm). Shimano switched to a 1.1mm wire in 1995, and back to 1.2mm in 1996.

### ***Integration with brake levers***

Certain shifters on MTBs share a mount with the brake lever. The configuration of the mount is specific to the model of shifter. When one of these older shifters needs replacement, it is possible that the brake levers and shifters will both need replacement.

### ***Symptom caused by multiple items***

When indexing shift performance is poor, the nature of the symptom will not necessarily point to one specific cause. A shifter, cable, derailleur, chain, or rear cogset could all cause the same symptom.

Patience to investigate all the possible causes of the symptom is required to narrow it down to, or to exclude, the shifter as the cause.

## ABOUT THE REST OF THIS CHAPTER

The rest of this chapter is divided into seven sections for each type of shift-control mechanism. Each section is divided into an installation sub-section and a service sub-section. Some sections are divided further, when different brands or models within a category require different procedures. The seven sections are:

**BELOW-BAR SHIFTERS**  
**TOP-MOUNT SHIFTERS**  
**TWIST-GRIP SHIFTERS**  
**INTEGRAL SHIFT/BRAKE LEVERS**  
**DOWN-TUBE LEVERS**  
**BAR-END SHIFTERS**  
**STEM SHIFTERS**

## BELOW-BAR SHIFTERS

### Types

Many below-bar shifters are integrated with the brake lever. They can be removed from the brake lever for cleaning or replacement, but to install and align them, the brake lever must be installed and aligned.

Another type of below-bar shifter is not integrated with the brake lever. This type needs to be positioned relative to the brake lever after correctly positioning the brake lever.

### Terminology

**Up-shift lever:** The lever that is pushed to move the derailleur from a smaller diameter gear (fewer teeth) to a larger diameter gear (more teeth).

**Release lever:** The lever that is pushed to release the derailleur to a smaller diameter gear (fewer teeth) from a larger diameter gear (more teeth).

**Shifter pod:** The complete shift-control mechanism that is part of an integrated shift/brake lever.

**Pod-mounting plate:** The flat plate that is part of the brake-lever body.

**Brake-lever binder bolt:** The bolt that secures the brake-lever clamp to the handlebar.

**Pod-mounting bolt:** The bolt that secures the shifter pod to the pod-mounting plate.

## INSTALLATION

### Integrated shift/brake levers

1. [ ] Remove grip if necessary.
2. [ ] Slide shift/brake lever over end of bar.
3. [ ] Install grip to final position.
4. [ ] Slide shift/brake lever outward until clamp is against inside edge of grip.
5. [ ] Remove and lubricate brake-lever binder bolt.
6. [ ] Install brake-lever binder bolt and gently snug.
7. [ ] With bike in on-ground position, use dial protractor to rotate lever so that brake lever body is 45° from horizontal.

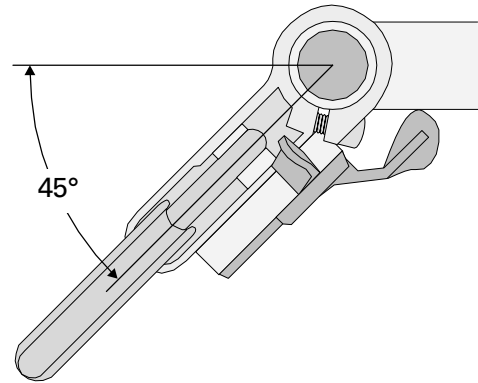

30.1 Rotate the brake lever 45° down from horizontal.

8. [ ] Tighten brake-lever binder bolt to: 35–50in-lbs (9–12lbs@4").

### Non-integrated below-bar shifters

1. [ ] Remove binder bolt from shifter-mounting strap or clamp.
2. [ ] Lubricate binder-bolt threads.
3. [ ] Install shifter, brake lever, then grip onto handlebar. Correctly position brake lever (adjacent to grip and rotated down 45° from flat), then secure brake lever.
4. [ ] Install shifter binder bolt and gently snug.
5. [ ] Slide shifter outward against brake lever, until release lever is just far enough outward to not touch brake lever when shifter is operated.
6. [ ] Rotate shifter so that shifters will operate in a plane 45° down from horizontal.

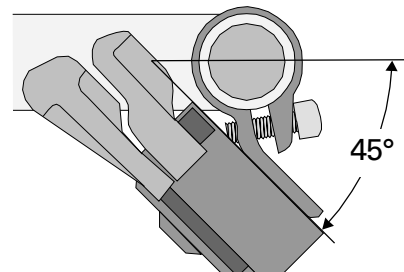

30.2 Rotate the shifter 45° down from horizontal.

## 30 – SHIFT-CONTROL MECHANISMS

8. [ ] Tighten shifter-clamp binder bolt to: 25–30in-lbs (6–8lbs@4").

### ***SunTour X-Press shifters***

The correct rotational alignment for these shifters is 60° down from horizontal (starting with shifters at horizontal *in front* of handlebars).

## INNER-WIRE INSTALLATION

### ***Shimano Rapidfire and Rapidfire Plus inner-wire installation***

Shimano Rapidfire levers (both levers pushed with the thumb) have a cover plate retained by a Phillips screw that has to be removed to access the inside of the shifter for inner-wire installation. Some Rapidfire Plus levers have a plug in the access hole for the inner wire. Rapidfire SL levers (described after the next heading), have a completely different cable-installation process.

Shimano Rapidfire and Rapidfire Plus (release lever operated by index finger) shifters need to be fully released in order to correctly install the inner wire. The wire can be installed without fully releasing the shifter, but the lever will not operate correctly.

1. [ ] Remove access cover plate if any.
2. [ ] Operate release lever at least 7 times to insure lever is fully released.

Earlier Shimano levers were difficult to install inner wires in, because once the inner wire was installed through the hole in the shifter drum it would not pass easily through the adjusting barrel. Sometimes it is necessary to remove the adjusting barrel from the shifter to complete the inner-wire installation.

3. [ ] Insert end of wire through access hole into inner-wire head socket and out adjusting barrel.
4. [ ] Pull inner wire through until head seats into socket in the shifter drum.
5. [ ] Pulling firmly on inner wire, push up-shift lever and then release lever to make sure wire moves to and away from shifter as levers are operated. (If not, inner wire is in wrong and should be removed.)

### ***Shimano Rapidfire SL inner-wire installation***

Shimano Rapidfire SL shift mechanisms are distinguished in appearance by the fact that there is a slot in the derailleur-cable adjusting barrel for quick-releasing the cable out of the shift mechanism. On less expensive models, there is a cover that swings out of place to expose the anchor for the inner-wire head. More expensive models have a similar cover, but instead of

swinging out of place, two tiny Phillips screws hold it in place. In both cases, the cover is accessed from the back face of the lever unit, just below the handlebar; where the inner-wire slot ends in the mount for the adjusting barrel, the cover begins. Underneath the cover is a pivoting cable anchor, just like the one in the brake lever that the brake inner wire attaches to.

1. [ ] Press release lever 7 times to make sure shift mechanism is in fully-released condition.
2. [ ] Remove cable-anchor cover by pivoting it up towards handlebar, or by removing small Phillips screws and lifting cover off lever (depending on model).
3. [ ] Line up slot in adjusting barrel with slot in adjusting-barrel mount.
4. [ ] Swing cable anchor up towards handlebar.
5. [ ] Hook inner-wire head into cable anchor.
6. [ ] Swing inner wire into slot in adjusting-barrel mount and into slot in adjusting barrel.
7. [ ] Rotate adjusting barrel 1/2 turn so inner wire will not accidentally come out.
8. [ ] Replace cable-anchor access cover.

### ***SunTour X-Press inner-wire installation***

1. [ ] Unscrew shifter cover screw at center of shifter cover and remove cover.
2. [ ] Feed inner wire out adjusting barrel.
3. [ ] Hook inner-wire head into socket in shifter plate inside shifter.
4. [ ] Replace shifter cover.

## SERVICE

Shifter pods can be replaced or cleaned, but they are never disassembled to replace individual parts because the individual parts are not sold.

### ***Shimano shifter-pod replacement***

Shifter pods are attached one of three ways at this time. First, a little orientation. The front of the shift/brake-control unit is the side that can be seen when standing in front of the bike and facing it. The back face is the side that would face toward the rider's knees. Some models have the shifter pod mounted on a plate that is visible from the front. There is a bolt head in the center of the shifter pod on the back face of the assembly. These will be called **exposed-plate models** (see figure 30.3, page 30-5). Some models have the shifter pod mounted on a plate that is enclosed between the shifter pod and the gear-indicator unit. There is a bolt head in the center of the shifter pod on the back face of the assembly. These will be called **enclosed-plate models** (see figure 30.4, page 30-5). Shimano Rapidfire SL models have an exposed plate, but there is no bolt head in the

center of the shifter pod (see figure 30.5, below, right). Rapidfire SL levers can also be identified by the unique fact that they have a slot in the derailleur-cable adjusting barrel that is used for moving the inner wire in and out of the adjusting barrel. This last type will be called Rapidfire SL models.

**Exposed-plate models:** To remove the shifter, loosen the bolt that is visible on the front face of the mounting plate. Note the rotational orientation of the shifter because it may have multiple mounting positions. When the bolt is fully removed, the shifter pod will pull off the back side of the plate. When reinstalling, make sure that the positioning pegs go into the desired positioning holes in the mounting plate. Use Loctite #222 on the mounting-bolt threads and torque the bolt(s) to 25in-lbs (6lbs@4").

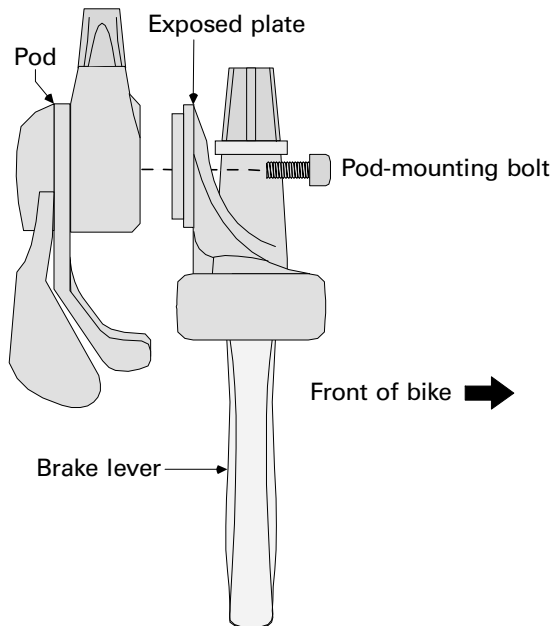

30.3 Removing the pod from the exposed plate.

**Enclosed-plate models:** The shifter-pod mounting bolt goes through the center of the pod and is accessed from the back face of the pod. It is often secured with a heavy-duty Loctite and may be difficult to break loose. The bolt is threaded into a sleeve nut with a flatted flange that is hidden behind the gear-indicator unit. The flatted flange tends to pop out of its recess and just spin, so pull out on the shifter pod firmly while loosening *or* tightening the mounting bolt. If the sleeve nut spins uncontrollably, it will be necessary to remove the gear-indicator unit. When installing the pod, make sure the lever is fully released so that the post on the colorful plastic plate that activates the gear indicator goes in the hole that is sup-

posed to engage it. Use Loctite #222 on the mounting-bolt threads and torque to 25in-lbs (6lbs@4"). On some models, the pod cannot be removed unless the gear-indicator unit is also removed. This includes STX and Alivio Models with "MC" in the model number, which are visually distinguished by having an enclosed mounting plate and an under-the-bar indicator unit.

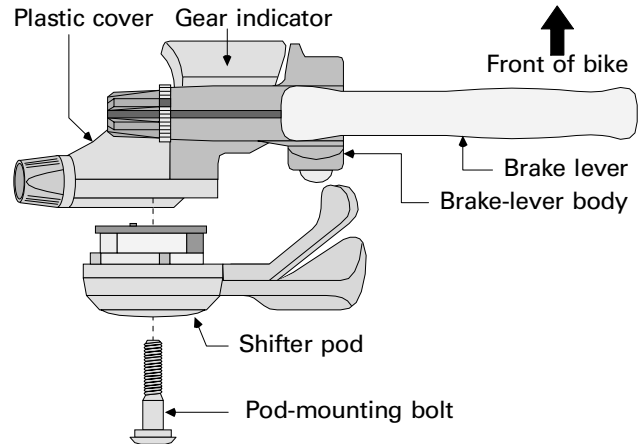

30.4 Removing the pod from an enclosed-plate unit.

**Rapidfire SL models:** Remove the gear indicator and the derailleur inner wire first. The shifter pod on these models is held in place by three Phillips screws. All the screws are on the back face of the pod. One is close to the derailleur-cable adjusting barrel. Another is just clockwise of the release lever. The third one is just counterclockwise of the release lever. One of the screws near the release lever will be hidden by the up-shift lever. When these three screws are removed, the shifter pod pulls easily of its mount. (See figure 30.5, below.)

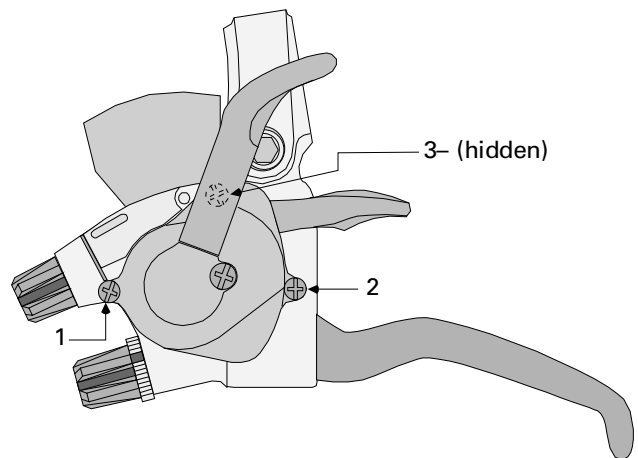

30.5 To remove the pod from a Rapidfire SL model, remove screws 1, 2, and 3.

### ***Shimano Rapidfire and Rapidfire Plus gear-indicator-unit replacement***

The following information covers gear-indicator removal and replacement for earlier Shimano Rapidfire and Rapidfire Plus models. There is another section following this one for Rapidfire SL models (distinguished by slot in derailleur-cable adjusting barrel). There are several ways that the gear indicator is mounted to the shift/brake control. When the pod is mounted to an *exposed-plate model*, the indicator unit comes off with the pod. These will be called **integrated type** (figure 30.6). Other types on *enclosed-plate models* may be over-the-bar or under-the-bar indicator units. All of these are not integrated with the shifter pod and come off separately. The under-the-bar type will be called **non-integrated under-the-bar type** (figure 30.7). The over-the-bar types come in *three* variations at the time of this writing! These will be called **hidden-screw over-the-bar type** (figure 30.8), **visible-screw over-the-bar type** (figure 30.9), and **Rapidfire SL type** (described under separate heading).

**Integrated type:** This is found on 700CX and 400CX models. After removing the pod from the mount, unthread two Phillips screws on the back side of the pod that are just below the indicator window. The indicator unit cover will lift off of the pod. The indicator itself is a thin sliding plastic strip that cannot be removed correctly without fully disassembling the pod unit, which *should not be done*. If the strip is damaged and jamming, it can be ripped out with a pair of pliers after removing the cover.

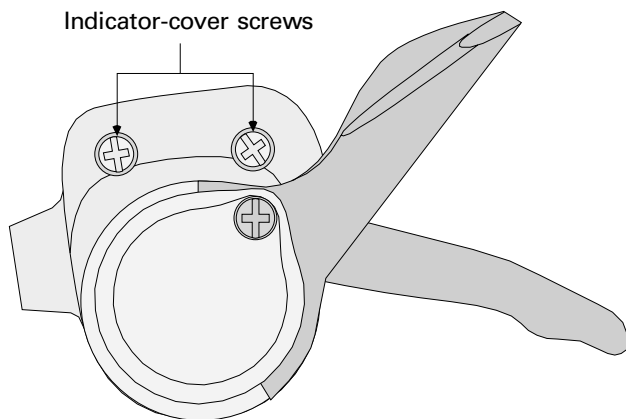

30.6 Shifting pod with an integrated gear indicator.

**Non-integrated under-the-bar type:** Remove two Phillips screws that are on the backside of the pod and just outside the perimeter of the pod cover, which rotates when the up-shift lever is operated. Remove the brake-lever reach-adjustment screw.

On the front side of the indicator unit, remove the Phillips screw that is adjacent to the brake-cable adjusting-barrel locknut. Lift off the indicator-unit cover. The orange indicator arm (spring loaded, be careful) just lifts out of the cover plate. When reinstalling the indicator arm, the spring must be set up to force the arm fully counterclockwise. The plastic actuator lifts out of the shifter-pod mounting plate to expose the flanged sleeve nut that the pod-mounting bolt screws into. When reinstalling, the pod unit needs to be shifted to the fully-released condition so that the long pin on the actuator will line up properly with the hole it inserts in.

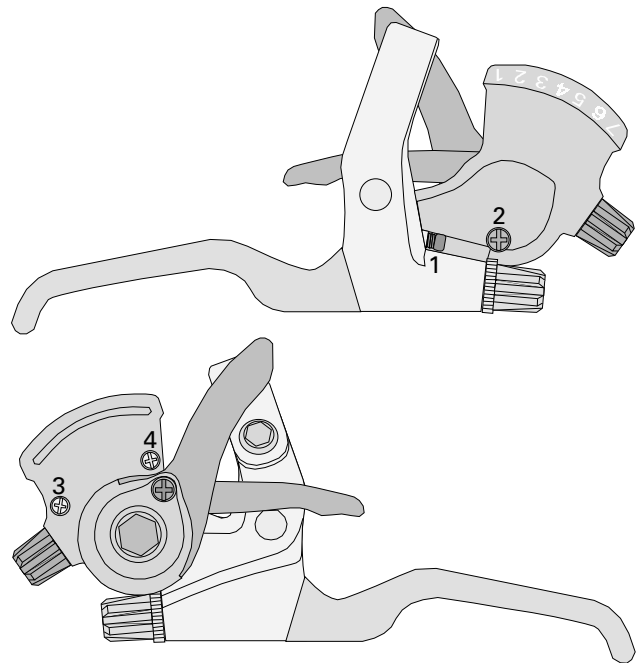

30.7 To remove an indicator unit from a non-integrated under-the-bar type, remove screws 1, 2, 3, and 4.

**Hidden-screw over-the-bar type:** When this type is on the handlebar, no screws can be seen in the indicator unit when viewed from the front. The whole shift/brake control must be removed from the handlebar to remove the indicator. Once the whole assembly is off the bar, one screw will become visible that was hidden by the handlebar. The other screw is on the back face of the casting just below the bottom of the shifter pod. Remove both these screws. *Do not remove the two screws in the indicator unit that are close to the window!* Remove the brake-cable adjusting barrel. On the front face of the control unit, the brake-lever reach-adjustment

screw must be removed so that the indicator unit can be lifted off. Pull on the indicator unit to remove it from the lever body.

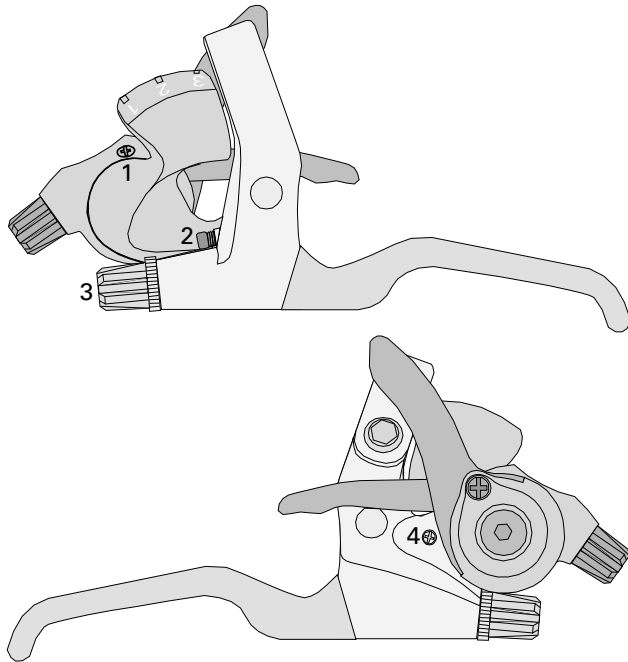

**30.8** To remove the indicator unit from a hidden-screw over-the-bar type, remove screws 1 and 2, adjusting barrel (3) and screw 4.

**Visible-screw over-the-bar type:** This type can be removed without removing the whole shift/brake control unit from the lever. Viewed from the front, small screws at the base of the indicator-unit tower and close to the brake-cable adjusting barrel will be seen. Remove these with a #0 Phillips screwdriver, and the indicator unit lifts right off. *Do not disassemble the unit!* The plastic actuator lifts up, and the mount cover snaps off.

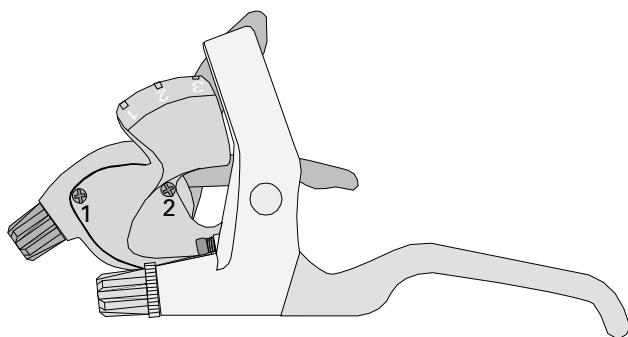

**30.9** To remove the indicator unit from a visible-screw over-the-bar type, remove screws 1 and 2.

### ***Shimano Rapidfire SL gear-indicator-unit removal and installation***

Rapidfire SL models are distinguished by a slot in the derailleur-cable adjusting barrel. The gear indicator is on the front face of the plate on which the shifter pod mounts. Removing two small Phillips screws enables the gear-indicator unit to be lifted off the mounting plate. An asymmetrical hexagonal plastic stud in the back face of the gear indicator engages an asymmetrical hexagonal socket that is in a hole in the mounting plate; if the shifter pod is in the fully-released mode when installing the gear indicator unit, the asymmetrical stud and socket will line up automatically. When installing the gear-indicator unit, the brake-lever reach-adjusting bolt may need to be removed in order to line the gear-indicator unit up properly.

### ***Shimano shifter-pod cleaning and lubrication***

Before replacing a shifter pod that is not functioning, consider cleaning and re-lubing it. To clean it, the pod must be removed from the mount and the cover must be removed from the pod. On pods with *integrated indicators*, the indicator cover should also be removed.

The technique for removing pod covers is different for different models. On *exposed-mount* types only, there may be a single large Phillips screw at the center of the pod cover on the back side. Some *exposed mount* types have an additional small Phillips screw at the perimeter of the pod cover that must also be removed. Some *exposed mount* types have only a small Phillips screw at the perimeter of the pod cover. All *enclosed mount* types have only a small Phillips screw at the perimeter of the pod cover.

The Rapidfire SL models have a small Phillips screw at the base of the up-shift lever that must be removed in order to remove the pod cover.

After removing the pod and cover(s), soak the pod in solvent. After it has soaked, agitate it in the solvent and repeatedly operate the levers while it is submerged. Blow it dry *thoroughly* and generously lube it with a heavy-weight spray lube.

## TOP-MOUNT SHIFTERS

### INSTALLATION

Top-mount shifters are installed inward of the brake levers. The shifter is above and in front of the handlebar.

The end of the lever extends to the grip, and if the lever is positioned too far outward the lever can interfere with use of the grip. Some models have cast clamps and must be slid on the bar from the end before installing the brake lever or grip. Some models have strap clamps that can be spread open and slipped over the bar while the brake lever and grip are in place.

1. [ ] **With brake lever and grip in final positions, mount shifter loosely, inward of brake lever.**
2. [ ] **Lubricate mounting-bolt threads and snug bolt gently so that shifter can easily be moved, but will stay in place by itself.**
3. [ ] **Operate shift lever so that lever is parallel to handlebar.**
4. [ ] **Move lever unit laterally so that end of lever is even with *and not overlapping* inward end of grip.**
5. [ ] **Rotate lever unit around handlebar until lever swings in a plane that is parallel to ground.**

Lever rotation is acceptable in a range from parallel to the ground, to rotated 45° forward. A position of 25–30° forward is recommended.

6. [ ] **Rotate lever forward to desired angle (25–30° recommended).**
7. [ ] **Secure mounting bolt to 20–25in-lbs (5–6lbs@4").**

### INNER-WIRE INSTALLATION

When installing the inner wire, thread it fully through the socket on the shifter drum so that the head ends up in the socket, *then* put the end of the wire through the housing stop or adjusting barrel and draw the wire fully through. Putting the wire partially through the hole in the shifter drum and then through the housing stop, before pulling the wire all the way through the hole in the shifter drum, will result in the inner wire developing a corkscrew bend.

### SERVICE

Look for a shifter-mounting bolt on the bottom side to remove the shifter from the mount. If there is a screw in the shifter cover, remove it. Soak and agitate the shifter in solvent, then blow dry and lubricate thoroughly. There is no point to disassembling the mechanism because there are no parts available.

## TWIST-GRIP SHIFTERS

### GRIP SHIFT

#### Models

The following instructions are suitable for models SRT 100/150, SRT 400i/300i/200i, SRT 500R, Quickshift, MRX-100, and SRT 400/600/800/900 (X-ray). These models were current in 1995 at the time of this writing. Models after this time may be similar or completely different.

#### Installation

1. [ ] **Loosen brake lever.**
2. [ ] **Slide Grip Shift shifting unit onto handlebar.**

The washer installed in the next step is very important because it keeps the shifter from binding against the grip.

3. [ ] **Slide 7/8" thin plastic washer onto handlebar.**
4. [ ] **Install grip fully onto handlebar.**
5. [ ] **Slide Grip Shift shifter outward so that it is against inward end of grip.**
6. [ ] **Secure brake lever at final rotational and lateral positions.**

For securing the Grip Shift to the handlebar, there is either a binder bolt or set screw with an Allen head. Either is located at the inward end of the unit, at a location that will be toward the back side and bottom, when the unit is on the handlebar with the adjusting barrel positioned just below the brake lever.

7. [ ] **Remove and lube mounting-binder bolt or set screw.**

Depending on the set-up of the frame and handlebars, the conventional positioning of the adjusting barrels below the brake levers might create an awkward cable routing. If this is the case, do not hesitate to try positioning the Grip Shift adjusting barrels above the brake-lever bodies.

8. [ ] **Rotate Grip Shift shifter until its adjusting barrel is just below brake-lever body, then install and gently secure binder-bolt/set-screw.**
9. [ ] **Operate brake lever to make sure Grip Shift does not interfere with operation and reposition shifter as necessary.**
10. [ ] **Secure set screw (2.5mm Allen) to 20in-lbs (7lbs@3"), or binder bolt (3mm Allen) to 17in-lbs (6lbs@3").**

#### Detaching cable

1. [ ] **Rotate shifter forward to fully release inner wire and disconnect inner wire from derailleur.**

### Cover-plate removal

Most Grip Shift mechanisms have a cover plate that must be removed for disassembly, but some do not.

If the inner wire is exposed in a groove around the bend at the base of the adjusting barrel, there is no cover plate.

If there is no exposed wire, look for a Phillips screw in the outward face of the base that goes out to the adjusting barrel (see figure 30.1). When the screw is removed, the plate comes right off.

If there is no exposed wire or Phillips screw, look for a shallow slot that just fits a 3/16" screwdriver blade on the inward face of the base that goes out to the adjusting barrel (figure 30.11). Insert a screwdriver in this slot and twist or pry to pop the cover plate off.

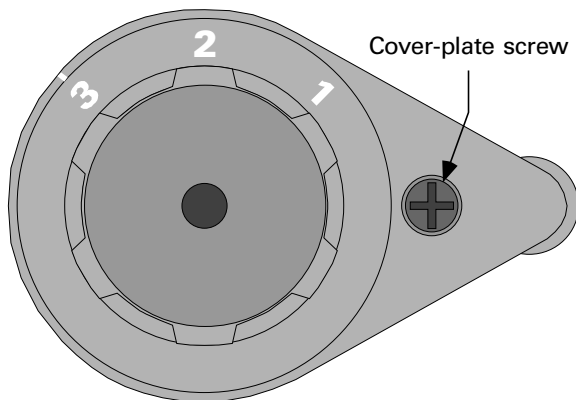

30.10 This outward-end view shows the Phillips screw that holds on the cover plate on some models.

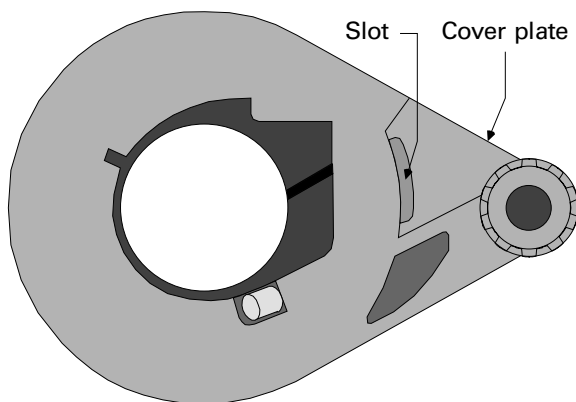

30.11 This inward-end view shows the slot used to pry off the cover plate on some models.

2. [ ] Remove cover plate on base that goes out to adjusting barrel.

### Removing twist unit and cable

3. [ ] Remove the grip and washer just outward of shifter.

If a cover plate was removed, the twist unit will pull out of the housing effortlessly. If the model had no cover plate, it must be rotated fully back (pulling the cable as far as possible) before pulling it off with some effort.

4. [ ] Pull twist unit out of housing. Models with no cover plate must be rotated *fully* back before pulling.
  5. [ ] Push inner wire into adjusting barrel until end is through and out of adjusting barrel.
- Some shifters have the inner-wire head inserted in a socket that is in the inward face of the shifter housing. Some shifters have the inner-wire head inserted in the large cylinder surface of the twist unit.
6. [ ] Push inner wire out of twist unit or out of shifter housing.

### Cleaning and lubrication

7. [ ] Parts should only be cleaned with a mild soap. Solvents may degrade plastic parts.
8. [ ] Lubricate shifter-housing barrel, spring, spring cavity, cable groove on way to adjusting barrel, and détentes in twist unit with Grip Shift Jonnisnot grease or petroleum jelly *only*.

**NOTE:** If inner-wire head is in twist unit, skip to step 12.

### Inserting inner wire in shifter with wire-head socket in shifter housing

**NOTE:** If wire is already installed, skip to step 14.

9. [ ] Feed wire end into socket on inward face of shifter housing and seat head fully.
10. [ ] Wrap wire one time around shifter-housing barrel and then into adjusting barrel, pulling so that loop ends up slightly smaller than diameter of enclosure.
11. [ ] Slide shifter onto barrel of housing and place loop of housing up feed ramp and into groove around inward end of twist unit, then go to step 14.

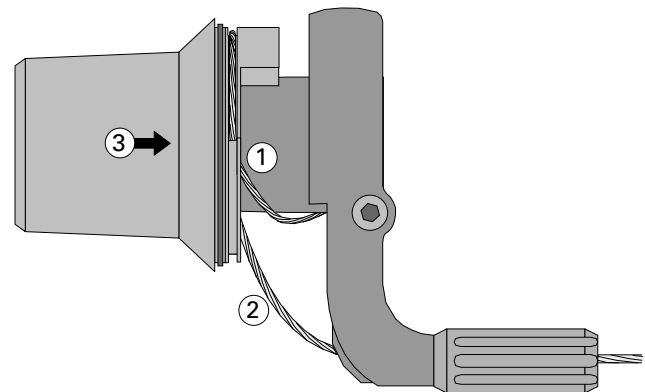

30.12 To install the inner wire: 1) wrap the wire once around the shifter-housing barrel, 2) feed the wire onto the ramp and into the groove around the twist unit, 3) then push the twist unit into the shifter housing.

## 30 – SHIFT-CONTROL MECHANISMS

### ***Inserting inner wire in shifter with wire-head socket in twist unit***

12. [ ] Insert wire into socket in twist unit, and seat head fully.
13. [ ] Slide twist unit onto barrel of shifter housing, and insert wire through adjusting barrel.

### ***Assembling shifter***

14. [ ] Line up twist unit so that any part of gear-indicator range on twist unit lines up with gear-indicator mark on shifter housing.
15. [ ] Pull firmly on inner wire while pressing in twist unit with firm pressure. Rotate twist unit back-and-forth to get spring to line up with détente, until parts seat together fully.
16. [ ] Install cover plate, if any.
17. [ ] Pull on inner wire while operating twist unit back-and-forth to check that cable moves and twist unit clicks in détentes.

## SACHS POWER GRIP AND POWER GRIP PRO

### ***Installation***

1. [ ] Install brake lever on handlebar loosely.
2. [ ] Slide shifter onto handlebar and leave loose.
3. [ ] If shifter has separate grip, slide both 7/8" I.D. washers onto handlebar and install stationary grip fully on, then slide shifter out gently against washers.
4. [ ] If shifter includes full grip, slide shifter fully on bar.
5. [ ] Position and secure brake lever.
6. [ ] Rotate shifter until adjusting barrel is just below brake-lever body.
7. [ ] Secure shifter bolts on bottom side of housing to 35in-lbs (12lbs@3").

### ***Inner-wire replacement and service***

Before performing the following procedure, confirm that the model being dealt with is one this procedure covers. The most current models do not require any disassembly for wire removal. Simply detach the inner wire from the derailleur and attempt to push it out of the shifter.

If this works, do not use the following procedure for inner-wire replacement.

1. [ ] Leave shifter on handlebar during disassembly.
2. [ ] Shift to release all cable tension and detach inner wire from derailleur and remove all cable housings.
3. [ ] ***Pull*** cable-adjusting barrel out of shift-mechanism cover.
4. [ ] Remove both bolts in bottom of shift-mechanism cover.

5. [ ] While holding bottom cover up against handlebar, pull cover off top of shift mechanism.
6. [ ] Pull lock button up out of back side of lower cover.
7. [ ] Pull J-ring off of top of inward end of twister.
8. [ ] Pull inner-wire guide out of front side of lower cover.
9. [ ] Drop lower cover off of handlebar and slide cover off end of inner wire.
10. [ ] If cleaning parts, remove grip and twister from handlebar.
11. [ ] Clean all parts, if desired.
12. [ ] Grease inside of twister & both sides of J-ring.
13. [ ] Install twister and grip on bar, if previously removed.
14. [ ] Insert inner wire into hole on twister.
15. [ ] Insert inner wire into back side of adjusting-barrel hole in lower cover.
16. [ ] Slide lower cover up inner wire and put lower cover on bottom side of handlebar so that lip on inner edge engages groove in bottom side of twister.
17. [ ] Holding lower cover up against bottom of handlebar, place lock button in back face of lower cover with tab going down into cover.
18. [ ] Place J-ring over inward end of twister so that pawl on inside surface of J-ring engages top-most détente in twister.
19. [ ] Rotating twister and deflecting end of J-ring as necessary, seat end of J-ring in slot in lower cover.
20. [ ] Install inner-wire guide in lower cover so that small end goes in back side of adjusting barrel hole and top end catches under shoulder on twister where inner wire first appears.
21. [ ] Place upper cover over mechanism.
22. [ ] Insert bolts in lower cover and gently snug.
23. [ ] Slide adjusting-barrel assembly over cable and insert nut on adjusting barrel into hole in lower cover.
24. [ ] Position and secure shifter as described in previous section, *Installation*.

## ***INTEGRAL SHIFT/BRAKE LEVERS***

### **INSTALLATION**

1. [ ] Pull out on rubber cover on outward side of shift/brake lever to reveal head of lever-mounting bolt and loosen bolt until almost out of nut in mounting strap.

2. [ ] Lubricate threads of nut in mounting strap.
3. [ ] Slide lever onto bottom of handlebar. If lever is correct for this side of bike, housing stop will point inward.
4. [ ] Snug mounting bolt so that lever can just be moved up and down.
5. [ ] Move lever up or down so that bottom tip of lever is .5" above or below line extended forward from bottom of bar.
6. [ ] Rotate lever so that it points straight forward.
7. [ ] Secure lever-mounting bolt to 70–85in-lbs (17–21lbs@4").

## SHIMANO STI SERVICE

### Terminology

**Shifter unit:** The entire lever assembly that pulls back to the handlebar to operate the brake, or pushes to the center of the bike to operate the gears.

**Brake/shift lever:** The primary lever, that is pulled back for braking and pushed inward to pull the derailleur inner wire.

**Release lever:** The secondary lever that is pushed inward to release the derailleur inner wire.

**Housing-stop/front-cover:** The cover in front of the head of the brake/shift lever. The housing-stop portion is the protrusion that points inward that has a socket in it for the cable housing to insert in.

**Lever-pivot stud:** A small axle that the shifter unit pivots on when pulling the brake/shift lever backward to operate the brake.

**Brake-lever housing:** The stationary body of the lever that attaches to the handlebar.

**Chrome adapter:** A large piece of chromed metal that connects the shifter unit to the brake-lever housing.

### Shifter-unit removal

1. [ ] While pedaling, operate release lever until chain reaches last gear, then detach inner wire from derailleur.
2. [ ] Remove cable housings and pull inner wire from all guides on frame.
3. [ ] Compress brake lever to handlebar to reveal cable head in socket in outward side of head of brake/shift lever.
4. [ ] Push inner wire into housing stop on inward side of lever and pull inner-wire head out outward side.
5. [ ] Remove entire brake lever from handlebar.
6. [ ] Loosen brake-lever-stud fixing screw using 2mm Allen key, one complete turn.

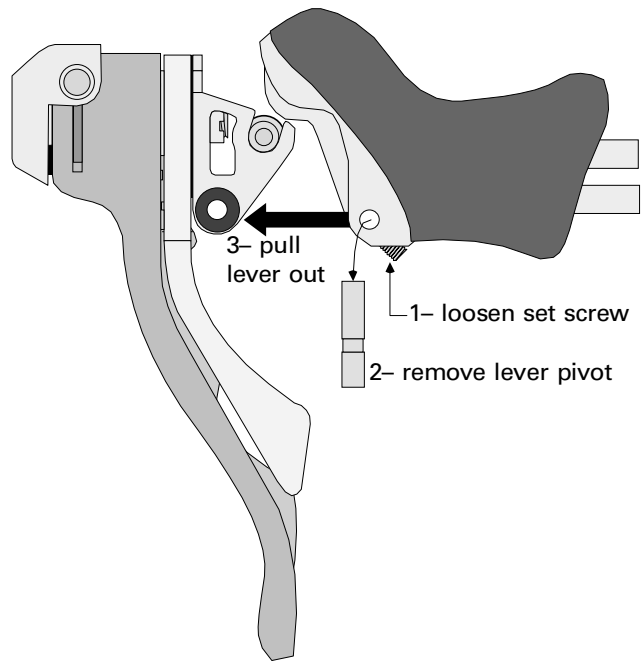

**30.13** To remove the shifter unit: 1) loosen the set screw, 2) push out the lever pivot, 3) then pull the shifter unit out of the lever body.

7. [ ] Operate brake lever to relieve pressure from brake-lever return spring and push brake-lever pivot stud inward using 4mm Allen or similar tool. (Note orientation of stud. Recessed portion of stud is on end to inward side of lever.)
8. [ ] Carefully remove lever assembly from lever housing. (Watch for lever bushings and lever-return spring that may fall out.)

### Dura-Ace models: lever-unit service

See figure 30.14 (page 30-12) for an illustration of steps #1–5.

**NOTE:** Perform shifter-unit removal before this procedure.

1. [ ] Gently pry cable-anchor pivot upward using small tipped screwdriver. (Note orientation of bushings and place on bundle.)
2. [ ] Remove retaining nut at back of shift lever by turning TL-ST01 with 5mm Allen wrench. (Hold tool square to nut and apply force toward nut while turning counterclockwise.)
3. [ ] Remove lock washer that was behind nut.
4. [ ] Remove chrome adapter and plastic dust cover together from lever assembly. (Note the spring is engaged on dust cover. Leave spring on cover.)
5. [ ] Remove small metal washer from splined stud.
6. [ ] Noting engagement of release lever to release plate, remove release plate from splined stud.

## 30 – SHIFT-CONTROL MECHANISMS

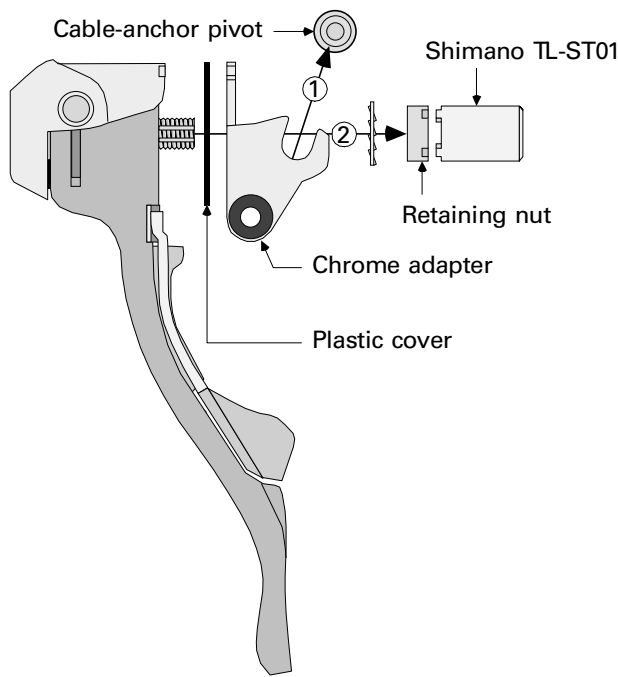

**30.14** To disassemble Dura-Ace shifter unit: 1) remove cable-anchor pivot; 2) remove retaining nut with Shimano TL-ST01 tool; then pull lock washer, chrome adapter, and plastic cover off of brake/shift unit.

7. [ ] Carefully clean and flush unit in solvent, taking care not to disturb internal parts.
8. [ ] Using care, dry with compressed air.
9. [ ] Lubricate pivot points with oil or light grease.
10. [ ] Install release plate (flat side out) onto splined stud, engaging tab on release lever to notch in release plate.
11. [ ] Install small metal washer over splined stud.
12. [ ] Install chrome adapter (includes plastic dust cover and spring) over splined stud.
13. [ ] Install lock washer over splined stud.
14. [ ] Apply Loctite 242 inside nut, install and secure nut to 50in-lbs (17lbs@3").
15. [ ] Lubricate and install bushings onto cable-anchor pivot.
16. [ ] Press cable-anchor pivot downward into slots in chrome adapter.

### **Non-Dura-Ace models: lever-unit service**

See figure 30.15 for steps #2–5.

**NOTE:** Perform shifter-unit removal before this procedure.

1. [ ] Ultegra models only, pry name plate off front of lever.
2. [ ] Remove fixing bolt and lock washer from front of lever.
3. [ ] Pull housing-stop/front-lever-cover off. (Note orientation of seal and spring behind cover.)
4. [ ] Looking at back side of lever assembly, move return lever to side to expose release-lever fixing screw and remove screw with #2 Phillips.

5. [ ] Separate release lever and brake/shift lever to expose internal mechanisms.
6. [ ] Carefully clean and flush unit in solvent, taking care not to disturb internal parts.
7. [ ] Using care, dry with compressed air.
8. [ ] Lubricate pivot points with oil or light grease.
9. [ ] Apply Loctite 222 to thread of shift-unit fixing screw.
10. [ ] Place cleaned and lubricated mechanism (or new mechanism) back inside brake/shift lever. Make sure mechanism is fully seated inside.
11. [ ] Move release lever to expose Phillips screw, and secure screw to 12–18in-lbs.
12. [ ] Apply Loctite 242 or 222 to threads of fixing bolt that holds on housing stop/front-lever cover.
13. [ ] Seat seal ring in groove in face of brake/shift lever.
14. [ ] Engage end of large coil spring into slot in back face of housing stop/front cover. (Only one end of spring may allow spring to fit easily into recess.)
15. [ ] Place housing-stop/front-cover over brake/shift lever so that end of spring in cover inserts into small hole in face of brake/shift lever.
16. [ ] Rotate cover approximately 90° in direction that housing stop points to, until square hole in cover lines up with flats on stud, then press cover onto stud.
17. [ ] Treat cover-fixing-bolt threads with Loctite 222 and install lock washer and bolt to 50in-lbs (17lbs@3").
18. [ ] Ultegra models, affix name plate to lever front with adhesive.

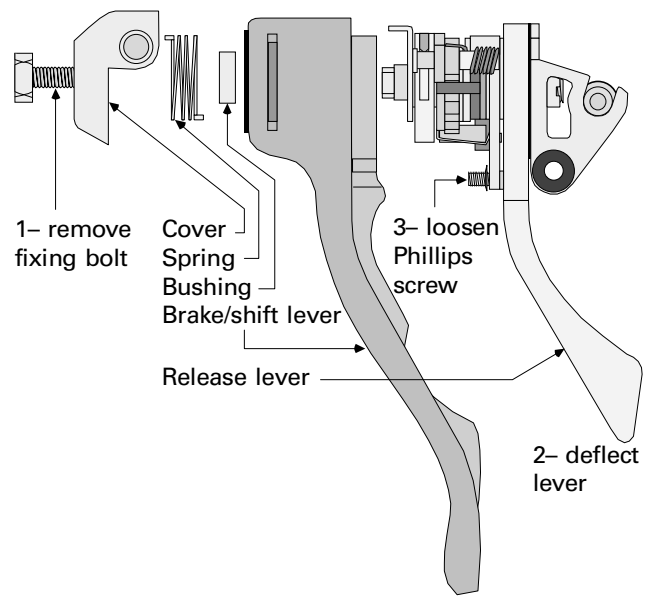

**30.15** To disassemble non-Dura-Ace lever-unit: 1) remove fixing bolt, 2) deflect release lever to side, 3) loosen the Phillips screw until the release lever and brake/shift lever will separate..

### **Shifter-unit installation**

1. [ ] Lubricate brake-lever bushings and install in chrome adapter. (Long bushing installs in outward side of chrome adapter, opposite housing stop.)
2. [ ] Place spring over longer bushing, with 90°-bend end engaged into small hole in chrome adapter.
3. [ ] Hold shift unit horizontally, with housing stop facing up.
4. [ ] Place TL-ST02 (or 3/32" tension/roll pin) over long end of spring.
5. [ ] Guide brake-lever housing onto shift unit and align lever-pivot-stud holes. This process may be awkward.
6. [ ] Insert lever-pivot stud from above, with end containing recess pointing up. (Recess must end up lined up with lever-pivot-stud set screw.)
7. [ ] Secure set screw.
8. [ ] Pull TL-ST02 off of spring.

### **Inner-wire installation**

1. [ ] Press release lever numerous times to make sure lever is fully released.
2. [ ] Compress brake lever so that head of lever moves out of brake lever housing.
3. [ ] Insert inner wire into socket on outward side of head of lever unit, then pull inner wire through housing stop until inner-wire head seats in socket.

## **CAMPAGNOLO/SACHS BRAKE/SHIFT-LEVER SERVICE**

### **Inner-wire and brake-lever removal**

1. [ ] Operate release lever to shift derailleur into most released position, and disconnect inner wire from derailleur.
2. [ ] Disconnect brake inner wire from brake caliper.
3. [ ] Un-tape handlebars and remove all cable housings from inner wires.
4. [ ] Remove rubber cover from lever.
5. [ ] Compress brake lever, push brake inner-wire head out of brake lever, and pull brake inner-wire fully out.
6. [ ] Push derailleur inner-wire so head comes out bottom of brake-lever body and pull derailleur inner-wire fully out.
7. [ ] Loosen Allen nut on outward side of top of lever body, then pull whole lever off of handlebar.

### **Disassembling and cleaning the shift mechanism**

1. [ ] Push release lever (the smaller inward lever) repeatedly to make sure mechanism is fully relaxed. (Do not operate lever again until work is completed!)
2. [ ] Levers with plastic bodies only, remove cover on bottom of lever body to expose shift mechanism.
3. [ ] Pull on brake lever to open and insert a 4mm L-shaped Allen wrench inside the front of brake lever into the 4mm-Allen fitting deep inside of lever body.
4. [ ] Secure this Allen wrench in soft jaws in vise.
5. [ ] Insert another 4mm Allen wrench into bolt in base side of brake-lever body. For right-hand lever, unthread bolt by turning clockwise. For left-hand lever, unthread bolt counterclockwise. Pulling up (from vise) on release lever will tip it so it does not apply side-load to bolt while bolt is being turned.

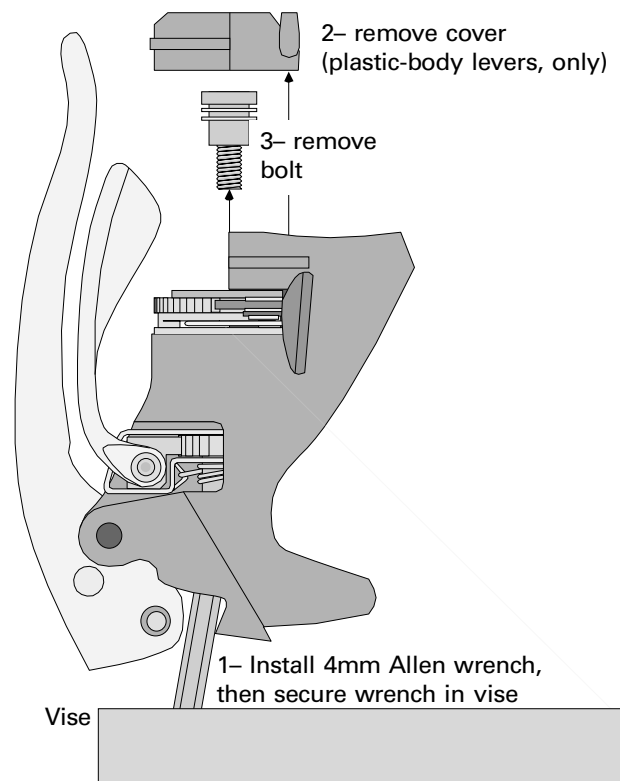

**30.16** To remove the release-lever retaining bolt: 1) install 4mm Allen into bolt head in brake-lever body, 2) remove plastic cover (plastic-body levers only), 3) remove bolt.

6. [ ] Pull up on release lever and use needle nose pliers to remove bolt.
7. [ ] Remove any shims under head of bolt. Note number of shims and bundle them together.

## 30 – SHIFT-CONTROL MECHANISMS

8. [ ] Tip release lever to disengage from spring, then rotate release lever approximately 90° to pull it out of brake-lever body.
9. [ ] Lift up toothed ring and pull partially out of brake-lever body until long end of spring clears spring hole in brake-lever body.
10. [ ] Rotate toothed ring approximately 180° and tip to pull out of lever body.

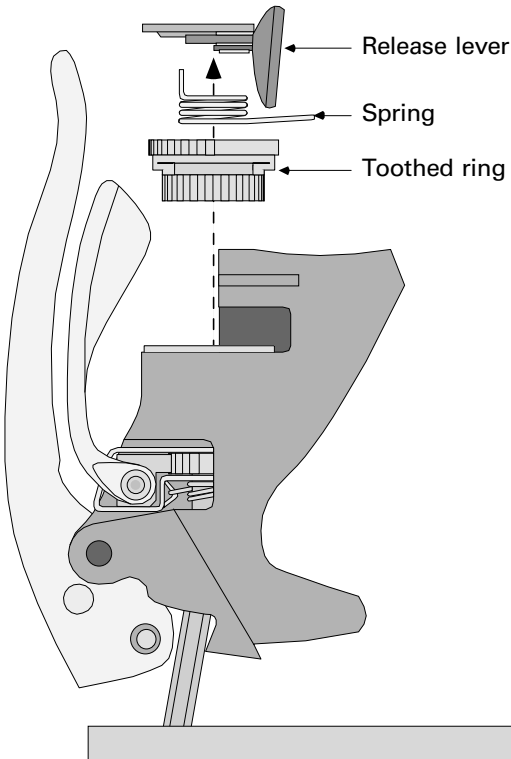

30.17 Remove release lever, spring, then toothed ring.

11. [ ] Note any washers under toothed ring and remove.
12. [ ] Lift prong on coil spring and gently pull spring out of toothed ring.
13. [ ] Use needle-nose pliers to remove two odd-shaped (indexing) springs down inside lever body that were exposed by removal of toothed ring.

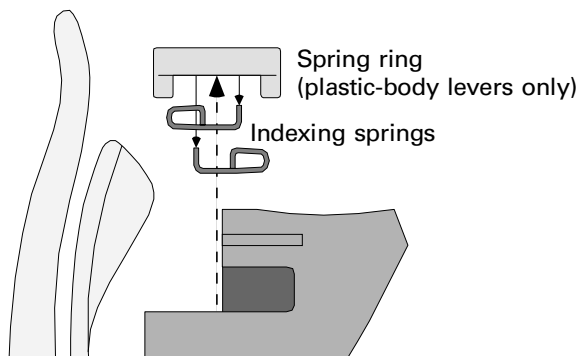

30.18 Removing the indexing springs.

14. [ ] Use small screwdriver or seal pick to gently encourage ring (in which indexing springs were mounted) out of lever body.
15. [ ] Further disassembly is possible, but not usually required. Cleaning of unit possible while still assembled. (To disassemble further, remove brake lever to better access internal parts. Remove snap ring from back of body to fully disassemble.)
16. [ ] Using care not to displace any internal parts, clean parts using mild solvents.
17. [ ] Carefully dry with compressed air.

### ***Assembling the shift mechanism***

1. [ ] Grease new indexing springs, grease inside indexing-spring mounting ring, as well as ring seat in lever body.
2. [ ] With flatter side of indexing-spring mounting ring facing down, install indexing springs into small holes so that curve of springs matches curve of mounting ring.
3. [ ] Install indexing-spring mounting ring into body, seating it on two studs.
5. [ ] Front levers have a split washer under toothed ring. Grease washer, and place on top of spring-mounting ring. (Align split with hole in lever body for release-lever spring.)
6. [ ] Grease outside and inside of toothed ring. Grease the return spring.
7. [ ] Place release-lever spring into toothed ring so that long end of spring sticks out of slot in toothed ring.
8. [ ] Aluminum body levers only, align toothed ring so that vertical-spring end enters big slot in lever body first, then slide toothed ring into lever body.
9. [ ] Rotate toothed ring so that horizontal end of spring points at spring hole in lever body.
10. [ ] Use tip of small screwdriver to deflect horizontal end of spring to line up with hole, then push toothed ring in all the way. (Indexing spring can displace below toothed ring and interfere. If this is difficult, removed toothed ring and make sure indexing spring is against wall of mounting ring.)
11. [ ] Rotate toothed ring so that flats in hole line up with flats on stud below, then drop toothed ring onto stud below.
18. [ ] With recess in release-lever disc facing up and end of lever pointing toward brake lever, insert release lever over toothed ring and engage release-lever spring into hole in release lever.

As an alternative to the previous step, put the release lever in place *without* engaging the spring, with the big hole in the disc lined up with the hole in the

toothed ring, and the release lever positioned where it stops against the lever body. Modify a very small slotted screwdriver by putting a notch in its tip and use this to guide the vertical end of the spring into the small hole in the disc of the release lever.

19. [ ] **Pivot release lever around end of spring until hole in release lever is centered over hole in toothed ring. (Expect this to be awkward since the spring will provide resistance.)**
20. [ ] **Reinstall any shims on retaining bolt. Apply Loctite 242 to threads of bolts.**
21. [ ] **Maintaining upward pressure on the end of the release lever to keep the spring down in the toothed ring, install and secure retaining bolt to 50in-lbs (17lbs@3"). Right-hand lever secures by turning bolt counterclockwise. Left-hand lever hand secures clockwise.**

## ***DOWN-TUBE LEVERS***

### **INSTALLATION**

#### ***Clamp-mounted shifters***

Clamp-mounted shifters have a strap that wraps around the down tube, with a binder bolt that pulls the ends of the strap together, located on the bottom side of the down tube. There is usually a small tab brazed to the top side or bottom side of the down tube that locates the shifters. The strap should be up the tube from the tab, but touching it. In case there is no tab, locate the shifters so that the ends of the levers come within 1–1.5" of the back side of the head tube. Secure the binder bolt to 24–30in-lbs (8–10lbs@3").

#### ***Braze-on mounted shifters***

Braze-on mounted shifters mount to brazed-on fittings mounted on both sides of the down tube. They sometimes have a unitized construction and go on all at once, and they sometimes are several parts that are placed on the braze-on one at a time.

If they are a single unit, simply slip them onto the braze-on and tighten the screw or bolt that goes through the center of the lever drum. The screw threads should be treated with Loctite 222, and the torque should be 10–15in-lbs (3–5lbs@3").

If they are friction (non-indexing) levers, they will usually consist of several parts. The first part is usually a plate that fixes to the large square at the base of the braze-on. This plate usually has a stop that stops the forward motion of the lever. If the plate is on wrong, the lever will not stop parallel to the down tube when pushed all

the way forward. The next part is usually a thick washer with a round hole in the middle. This is followed by the lever itself. After the lever is another washer that usually has a flatted hole that engages the flats on the end of the braze-on. A cover plate typically follows this, and the last part is the mounting/tension screw that holds everything on and adjusts the amount of friction. This screw should be oiled, not treated with Loctite.

If the lever has too much friction and will not operate smoothly without loosening the tension screw to the point that it will not resist the derailleur return spring, try lubricating both faces of the lever where it is sandwiched between the washers.

### **SERVICE**

If the lever comes off as a unit, then the only service is to soak it in solvent, dry with compressed air, and inject oil. If this does not solve the problem, the lever must be replaced.

Levers that come off in parts when the central screw is undone can be cleaned thoroughly, dried, then lubricated and installed. In rare cases, the washers that sandwich the lever can be replaced (if worn out).

## ***BAR-END SHIFTERS***

### **REMOVAL**

The shift mechanism usually must be removed from the mount to access a bolt that secures the mount inside the handlebar. Turn the bolt *clockwise* to loosen the mount. If the bolt will not turn clockwise without stripping the Allen socket, turn the mount counterclockwise.

### **INSTALLATION**

The shift unit must be removed from the mount to install the mount in the end of the handlebar. When installing, be sure to grease the mounting-bolt threads *and* the inside and outside surfaces of the expander that fits inside the handlebar. Align so that shifter will point straight down and torque bolt (counterclockwise) to 50in-lbs (12lbs@3").

### **SERVICE**

Bar-end shifters usually have a unitized construction. The only service is to soak in solvent, dry, and oil. If problems continue, replace the shifters.

# STEM SHIFTERS

## INSTALLATION

Stem shifters are installed on the vertical shaft of the stem. They should be mounted as close to the headset locknut as possible, unless this position causes the

cable housings to deflect awkwardly around the headset. Lubricate bolt threads and torque bolt to 50in-lbs (12lbs@3").

## SERVICE

Stem shifters can be disassembled, cleaned and oiled. There are no individual parts available, so non-functional levers should be replaced as a unit.

# SHIFT-CONTROL-MECHANISM TROUBLESHOOTING

<b>Cause</b>	<b>Solution</b>
<b>SPECIAL NOTE:</b> <i>All shifting problems can easily be caused by other parts of the drive train. Always check derailleur, shifter, cable, chain, and gear compatibility before assuming the problem is with the shift-control mechanism. Check for cable-friction problems, derailleur wear, and chain wear, also.</i>	
<b>SYMPTOM:</b> <i>Shimano Rapidfire lever will not operate.</i>	
Inner wire was installed when lever was not fully released.	Remove inner wire and install when lever is fully released. Remove pod cover if necessary.
Internal mechanisms are dirty.	Remove pod and pod cover, soak in solvent, dry, and oil.
Parts have failed internally.	Replace pod after checking for first two causes.
<b>SYMPTOM:</b> <i>Grip Shift does not allow derailleur to align with cog after completing shift.</i>	
Inside of Grip Shift needs lubrication.	Disassemble Grip Shift, clean, and lubricate.
Grip Shift is worn out internally.	After eliminating other possible causes, replace shifter.
<b>SYMPTOM:</b> <i>Shimano rear derailleur operated by Grip Shift will not shift to outermost cog without hesitation when derailleur adjustments, shifter lubrication, and cable setup are all good.</i>	
Some models of Shimano derailleurs had too light a return spring to pull the cable through the Grip Shift even when everything was set up correctly.	An additional spring can be installed on the derailleur (see page 32-??), or a Grip Shift Bassworm can be added to the cable system.
<b>SYMPTOM:</b> <i>Shimano STI integrated shift/brake levers on road bike will not stay in a gear after shifting inward.</i>	
Internal part in shifter has failed.	Contact Shimano for warranty.
<b>SYMPTOM:</b> <i>Friction-type shift lever will not hold its position after completing the shift.</i>	
Tension/mounting screw needs to be tightened.	Tighten tension/mounting screw.
<b>SYMPTOM:</b> <i>Friction-type shift lever is sticky at loosest tension setting that will hold against derailleur return spring.</i>	
Friction washers need lubrication.	Drip oil in crevasses on both faces of lever drum, or disassemble shifter and lubricate faces directly.

### 30 – SHIFT-CONTROL MECHANISMS

<b><i>Cause</i></b>	<b><i>Solution</i></b>
<b>SYMPTOM:</b> <i>Friction-type shift lever will not hold its position after completing the shift, no matter how much the tension screw is tightened.</i>	
Friction washers that sandwich lever are worn out.	Replace washers, if parts available.
Slick-plastic friction washers that do not need lubrication have been oiled.	Disassemble lever, clean washers with alcohol, and re-install.
Tension/mounting screw is not screwing fully into braze-on because of interference in hole.	Put washers under head of tension/mounting screw.
<b>SYMPTOM:</b> <i>Braze-on-mounted down-tube friction lever keeps loosening up after proper friction tension has been achieved.</i>	
Flats in hole in outer friction washer are a loose fit to flats on braze-on stud.	Replace outer friction washer.
If washer is fresh, braze-on flats are under-sized or worn.	Deform washer to create tighter fit, or find shim stock to jam between washer and braze-on flats.
<b>SYMPTOM:</b> <i>Mounting screw will not start threading into braze-on when installing down-tube shifter on braze-on.</i>	
5 × .8mm mounting screw is being installed in braze-on with more rare 4.5mm thread type.	Replace screw with correct size, or install shifter that comes with correct screw.
Threads in braze-on are damaged.	Chase thread with correct tap (usually 5 × .8mm)
<b>SYMPTOM:</b> <i>Campagnolo/Sachs integrated brake/shift levers are difficult to operate when pressing on the release lever.</i>	
Levers are new and need to break in.	Make sure lever is clean and lubricated, and if so, allow adequate time for break-in.
Levers are dirty internally.	Disassemble, clean, and lubricate.

