

# 26 – CHAINS

## ABOUT THIS CHAPTER

This chapter is about removing, replacing, installing, cleaning, and lubricating chains. Bikes without derailleurs typically have chains with master links. Master links are covered in a separate section, as well as information about sizing and tensioning chains on non-derailleur bicycles.

## GENERAL INFORMATION

### TERMINOLOGY

**Side-plates:** The usually dog-bone-shaped plates that are seen when looking at the chain from the side. Side-plates come in two versions on every chain: inner side-plates and outer side-plates. The outer side-plates are the ones that are seen in their entirety when viewing the chain from the side. The inner side-plates are the ones hidden partially by the outer side-plates.

**Rollers:** The metal cylinders that are between the inner side-plates.

**Bushings:** Not all chains have bushings. Bushings are metal cylinders that are inside the rollers and cannot be seen when the chain is assembled. Normally there is no need to be concerned with whether a chain has bushings or not.

**Rivets:** The round metal rods that protrude just beyond the face of the outer side-plates. Each roller goes through an outer side-plate, an inner side-plate, the roller, another inner side-plate, and another outer side-plate. The rivets are what hold the chain together. They work by friction and are jammed into undersized holes in each outer side-plate, but slip easily through the inner side-plates and the roller.

**Link:** The smallest complete section of chain. It consists of two outer side-plates, two inner side-plates, two rollers, and two rivets. If a unit with only two inner side-plates was removed or added (one roller and one rivet), then the chain would be left with both ends ending in outer side-plates, which cannot be joined together. A full link, including four side-plates, has an effective length of one inch, measured from the center of the rivet at one end to the center of the rivet hole at the other end.

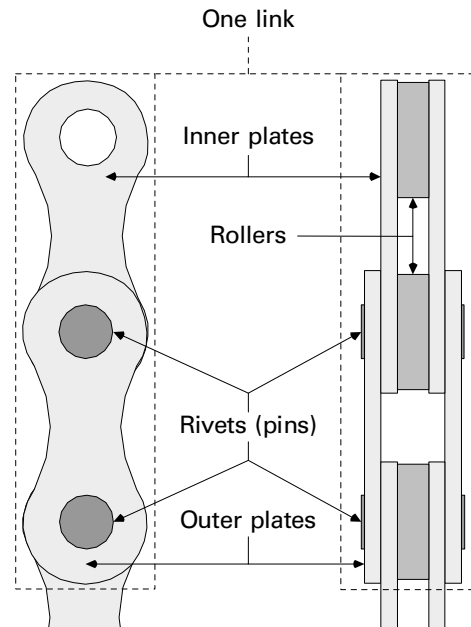

26.1 These are the parts of the chain.

**Half-link:** A section of chain including only two side-plates.

**Narrow chain:** Chains for derailleur bicycles have been made in several widths. The widest part of the chain is the rivet, so the chain width is a measurement of the rivet length. A narrow chain's rivet length cannot exceed 7.4mm. All modern chains have a narrow configuration, and narrow chains are compatible with all derailleur bicycles, even those made when the only chains that existed were wide chains.

**Wide chain:** The original chains for derailleur bicycles had a width (measured by measuring the length of the rivet) of 7.6mm or more. These are sometimes called *normal* because they existed first, but they have become extremely rare, so in this book the designation *wide* is used. Wide chains are only compatible with bikes that have wide spacing between the rear cogs and between the chainrings. It is not important what this spacing is because virtually all replacement chains today have a narrow configuration. Narrow chains are compatible with freewheels and chainrings that were made for wide chains.

**Peened:** When a rivet is installed at the factory, the ends of it are deformed so that they become fatter and will not pass through the hole in the outer side-plate as

## 26 – CHAINS

easily. Sometimes this deformation is created by striking the pin at two points with a chisel-like tool. This is called *double-peened*. When a rivet is double-peened, the end of it will have two parallel grooves in it. A rivet can also be *fully-peened*. A fully-peened rivet has been deformed all the way around its perimeter. This may be visually apparent if it has been done in a crude fashion, but it may not be obvious. If a rivet does not appear to be double-peened, then assume it is fully-peened.

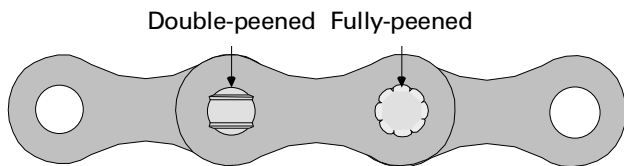

26.2 The left rivet is the end of a double-peened rivet. The right one is fully-peened.

**Chain stretch:** As chains are used, they become longer. This is often called *stretch*, which is a misnomer because nothing actually stretches. The reason that chains become longer is that wear occurs between the rollers and the bushing, or rivet inside the roller. This wear creates slop or free play between the various parts of the chain, which makes the chain longer. More important than the change in length is the fact that the distance from roller-to-roller increases minutely from the original half inch, which means that the chain will not mesh well with the gear teeth, which are spaced at half-inch intervals. As a consequence of this wear, the chain also develops more lateral flexibility, which affects its shifting performance long before the poor mating to the gear teeth becomes an issue.

**Hyperglide-compatible chain:** Shimano makes freehubs and freewheels that are called Hyperglide. These have a special configuration to the teeth that make it possible for the chain to simultaneously engage two cogs when being shifted. Non-Hyperglide systems work by the chain disengaging one cog, before engaging the next. When Hyperglide-compatible is used with regard to a chain, it implies that the shaping and strength of the chain are suitable for use with a Hyperglide cog set. Shimano does not provide other manufacturers with any standards for what makes a chain Hyperglide compatible, so it is up to the manufacturers of Hyperglide-compatible chains to define that compatibility. There is no guarantee that a chain called Hyperglide-compatible will perform in the same way as a Shimano Hyperglide chain.

**Hyperglide-compatible chain tool:** The term “Hyperglide-compatible” is also used in regard to chain tools. The Shimano Hyperglide chains have special shap-

ing to the side-plates and unusually tight rivets that put special demands on a chain tool. Once again, Shimano does not provide any standards to other manufacturers in this area, so the term Hyperglide-compatible does not guarantee proper results. The fact that a tool is described as Hyperglide-compatible never makes it less suitable for non-Hyperglide chains, and often makes it a better choice for a non-Hyperglide chain.

**IG chain:** The latest descendant to the Shimano Hyperglide chain. All information about Hyperglide chains with regard to tools and rivet techniques applies to IG chains.

## CHAIN DIMENSIONS AND TYPES

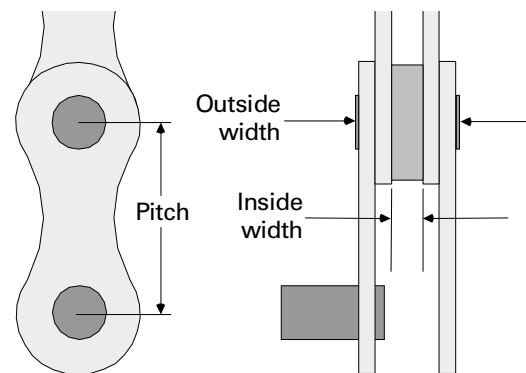

26.3 Chain dimensions.

There are two basic types of chains:  $1/2" \times 3/32"$  (derailleur bikes), and  $1/2" \times 1/8"$  (non-derailleur bikes). A bike must use a  $1/2" \times 1/8"$  chain if the teeth on either the front or rear gears are wider than 2.6mm (usually approximately 2.7mm). All bikes with coaster brakes, most bikes with internally-gear hubs, some BMX bikes with freewheels, and some track bikes require the  $1/2" \times 1/8"$  size.

These numbers that name the chain size (for example,  $1/2" \times 3/32"$ ) refer to the pitch of the chain and the inside width. See figure 26.3 above to determine the parts of the chain to which these dimensions apply.

The  $1/2" \times 3/32"$  derailleur-bike chains vary in outside width. These outside widths fall into three categories: wide chains, narrow chains, and super-narrow chains.

### Wide chains

Wide chains are virtually unused today, except on older bikes. They have an outside width of 7.6mm or more, but are generally wider than 8mm. Narrow and super-narrow chains can always be used where a wide chain is being replaced.

### ***Narrow chains***

Narrow chains have an outside width of 7.2mm to 7.4mm. They are *required* for use on most 6-speed cog sets and all 7-speed cogsets. They are adequate for use on most 8-speed cogsets, although they may be slightly noisier than super-narrow chains.

### ***Super-narrow chains***

Super-narrow chains always have an outside width of about 7.2mm. They are preferred, but usually not required, on 8-speed cog sets. They can be used on any other cog sets just as well.

### ***Nine-speed chains***

Nine-speed chains have an outside width of 6.6–6.8mm. They are required on 9-speed cog sets. They can be used on any other cog sets just as well.

## **PREREQUISITES**

There are no prerequisites to chain removal, replacement, installation or service.

## **INDICATIONS**

### ***Maintenance cycles***

There are two types of maintenance that need to be performed on chains. The first is cleaning and lubricating. Chain cleaning should be performed whenever the chain is obviously dirty. Differences in riding conditions make it impossible to put a time or mile value on this need. It could even be after every ride. This is especially true of mountain-bike chains. Lubricating should be done whenever the chain is cleaned, or whenever it develops a chirping or squeaking noise and is not dirty. On the other hand, routine chain oiling can lead to a chain getting dirty faster, so only oil when there is need.

The second type of maintenance is routine checking for excessive chain wear. Waiting for symptoms to develop will lead to increased wear of expensive rear cogs and chainrings. Replacing chains *before* they get worn out is more economical than getting full life out of them, and prevents problems with shifting performance. Check chain wear every 500 miles on road bikes, and every 100 miles on off-road bikes.

On a new bike, it is important to make a simple inspection to determine whether all the rivets are correctly installed. It is not unusual for the factory to fail to install a rivet completely, which eventually leads to the chain breaking. Look on both faces of the chain for any rivet protruding significantly more than the others.

New chains (and chains on new bikes) are coated with a rust-preventive compound that is usually a less-than-ideal chain lubricant. The stickiness of this compound makes it inclined to collect dirt. To maximize chain life, clean and lubricate new chains or chains on new bikes immediately. This cleaning time might be difficult to cost-justify, in which case it should turn into a recommendation to the customer.

### ***Symptoms indicating worn chain***

Poor shifting can result from a worn or dirty chain. If after performing all possible derailleur service and cleaning the chain, the shifting is still not as good as when the chain was new, wear is probably significant.

When a chain wears too much, the distance from roller to roller increases to the point that the chain and gear teeth do not fit together properly. Chain wear is usually detected when installing a new freewheel or cog(s) while keeping a used chain, or installing a new chain on worn cogs. In these situations, a loud metallic “clunk” is heard from the rear of the drive train, and the pedals jump forward and catch again. This symptom is strictly experienced when there is high load on the chain. What is actually happening is that as the chain feeds on to the bottom of a rear cog, a roller sits on top of a tooth instead of between the teeth. When this roller reaches the top of the cog, the load on the chain forces the roller on top of the tooth to drop down between the teeth, so the chain suddenly jumps forward a quarter inch or so. This makes a loud noise. Depending on the size of the chainring that the chain is on when this occurs, the pedals will seem to slip forward an inch or two and then catch again.

### ***Symptoms indicating need of lubrication***

Chirping or squeaking sounds may come from the chain while pedaling. This is a sure sign that the chain is overdue for lubrication. Initially the sounds may be intermittent, occurring at an interval that takes more than one crank revolution to reoccur. This is because the link that needs lubrication is most likely to make noise as it passes through the rear derailleur. When the chain has just been cleaned and oiled and this symptom occurs, it indicates that there is still solvent in one or more of the links that is displacing the lubricant, or that the chain was not completely lubricated.

### ***Symptoms indicating a tight link***

A tight link is a link that does not pivot freely, and manifests itself as a clunk that occurs once per chain revolution. With the bike in the stand, pedal backwards slowly, then look for a link holding its bend at the point the chain comes out of the rear derailleur.

## 26 – CHAINS

This could be caused by three things: 1) if only one tight link develops immediately after installing a chain, it means that the four side-plates where the rivet was pressed in are tightly compressed against each other and the symptom will go away once a tight-link-elimination procedure is performed; 2) dirt can cause a tight link, and the only solution will be to clean the chain; 3) lack of lubrication or rust can cause a tight link. If rust is the cause, try adding oil. If this solves the problem, fine. If rust is present and oiling does not eliminate the tight link, then the chain needs to be replaced.

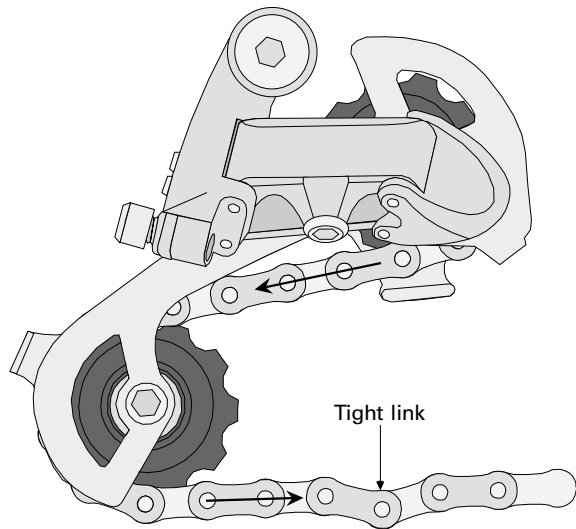

**26.4** Pedal backwards and watch the lower pulley wheel to detect a tight link. As the tight link goes by each pulley wheel, it may cause the derailleur cage to jump a little. If you stop pedaling right away, the tight link should be visible just in front of the lower pulley.

### **Symptoms indicating need of cleaning**

New chains (and chains on new bikes) are coated with a rust-preventive compound that is usually a less-than-ideal chain lubricant. The stickiness of this compound makes it inclined to collect dirt. Cleaning and lubricating new chains or chains on new bikes will maximize chain life, but whether the time spent cleaning would be considered cost effective is another matter.

A dirty chain will cause an advanced rate of wear, so do not wait for a symptom to lead to cleaning a chain. A dirty chain will develop tight links, will shift poorly, and contributes to “chain suck,” a condition where the chain remains stuck to the small chainring and jams into the chain stay.

### **Symptoms indicating damaged chain or protruding rivet**

A clunk or click may come from a chain at regular intervals less than once per crank revolution. If this symptom is not caused by a tight link, then it

could be caused by twisted side-plates or a protruding rivet. First, inspect both faces of the chain for a rivet protruding farther than the others. If this is not found, then remove the chain and hang it vertically. If the chain develops a twist over its length, so that the uppermost links do not face the same way as the lowermost links, then the chain has one or more twisted side-plates and should be replaced. Twisted side-plates usually are caused by the chain jamming somewhere when there is a mis-shift (chain comes off gears).

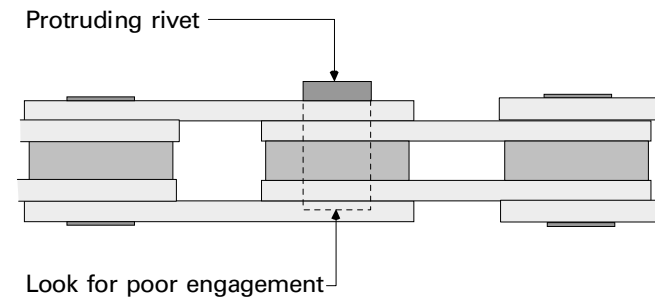

**26.5** When a rivet is installed inadequately, the protrusion at one end is more obvious, but the less obvious poor engagement at the other end is what leads to chain failure.



**26.6** This chain is twisted.

### **Derailleur removal and installation**

It is optional to remove and re-install the chain when installing or removing either derailleur. The cage of either derailleur can be opened instead of separating the chain.

### **Freewheel or cog replacement**

It is a good idea to replace an even moderately-worn chain whenever installing new rear cogs. A worn chain greatly accelerates the wear on the cog teeth.

## **TOOL CHOICES**

The design or brand of chain will determine the tools needed. Table 26-1 (page 26-5) covers all the tools for the job. The preferred choices are in **bold**. A tool is preferred because of a balance among: ease of use, quality, versatility, and economy. When more than one tool for one function is **bold**, it means that several tools are required for different configurations of parts.

Shimano chains have a design that is very demanding on the chain tool. If the wrong tool is used, then the chain or the tool is likely to be damaged. The damage to the chain may be subtle and could result in a

mysterious chain break at a later time. Several tool manufacturers make “HG-compatible” chain tools, but none of these tools work as well as the Shimano tool designed for the job (and most are completely unacceptable). The Shimano chain tool that is recommended in the list is very expensive by chain-tool standards, but has proven to work well on virtually *all* chains, is durable, and is a pleasure to work with. Despite information that might be seen in print elsewhere, it is perfectly suitable for non-HG chains. Few mechanics that have ever used the Shimano TL-CN31 in the shop have ever considered it to not be worth the money.

## TIME AND DIFFICULTY

### *Chain removal and installation*

Chain removal and installation is a 3–5 minute job of little difficulty, but if not done with care it is easy to damage the tool or the chain.

### *Chain cleaning*

Chain cleaning is a 5–15 minute job of little difficulty, but does require elbow grease in some cases. Additional time is required if not using compressed air to remove the solvent from the chain. Thorough drying is critical, and it could take a few hours in the hot sun or all day and overnight to thoroughly dry a chain on the bench top or on the bike.

**CHAIN TOOLS** (table 26-1)

Tool	Fits and considerations
<b>INSTALLATION AND REMOVAL TOOLS</b>	
Campagnolo 1130020	Plier-type tool, not HG/IG compatible
Cyclo Rivoli 158	Consumer use only
Cyclo Rivoli 158R	Use for tight-link removal only, non-HG/IG chains only
Finish Line Chain Pup	Consumer use only
Hozan C301	Screw-type tool, not HG/IG compatible
Hozan C320	Plier-type tool, not HG/IG compatible
Lifu 60UO	Consumer use only
Off Dirt Quick Link QL4	Consumer use only
Park CT-2	Plier-type tool, not HG/IG compatible
<b>Park CT-3</b>	Screw-type, HG/IG compatible, best for tight-link removal
Park CT-5	Consumer use only
Rohloff Revolver 2	Screw-type tool, not HG/IG compatible, prevents occurrence of tight links
Shimano TL-CN22	Consumer use only, HG/IG compatible, 9-speed compatible
<b>Shimano TL-CN31</b>	Screw-type tool compatible with all chains (inc. 9-speed), durable, easy to use
VAR 06	Screw-type tool, not HG/IG compatible
VAR 303	Plier-type tool, not HG/IG compatible
VAR 303ST	Plier-type tool, not HG/IG compatible
<b>WEAR-MEASUREMENT TOOLS</b>	
<b>Park CC-2</b>	Numerical gradations, accurate and consistent
Rohloff Caliber 2	Simple “no go” gauge, accurate and consistent
Speedtech CW-1089	Measures four degrees of wear, difficult to get consistent results
<b>CLEANING TOOLS AND COMPRESSORS</b>	
“On-the-bike” chain cleaners, all brands	Useful for cosmetic cleaning or consumer use only
<b>Park GSC-1</b>	Good stiff brush for cleaning chains and cogs
Off Dirt QL1	Compresses chain for working on without tension, unneeded if using TL-CN31
VAR 424	Compresses chain for working on without tension, unneeded if using TL-CN31

## COMPLICATIONS

### *Identifying chain as narrow or wide*

When performing certain operations, it is important to know whether the chain is wide or narrow. It is not essential to distinguish the difference between narrow and super-narrow chains for the purposes of the following procedures. Determining chain width is simply a matter of measuring the rivet length. If the measurement is 7.4mm or less, the chain is narrow.

### *Identifying whether a chain is Hyperglide/IG or non-Hyperglide/IG*

When performing certain operations, it is important to know whether the chain is a Hyperglide chain or not. With extremely few exceptions, a Hyperglide chain will have the marking “HG” or “IG” stamped on the outer side-plates. Some early models of the chain were marked “UG,” but not all UG chains are Hyperglide. If a narrow chain marked UG is assumed to be a Hyperglide chain and it is treated as such, no serious consequences will arise if you are wrong. On the other hand, if a Hyperglide chain marked UG is treated as though it were a non-Hyperglide chain, rivet failure may be experienced. If you treat any narrow chain marked UG or HG as a Hyperglide chain, there shouldn’t be any problems.

## ABOUT THE REST OF THIS CHAPTER

The rest of this chapter is in four parts. These are **DERAILLEUR-CHAIN SERVICE**, **NON-DERAILLEUR CHAINS**, **CHAIN TROUBLESHOOTING**, and **EIGHT- AND NINE-SPEED COMPATIBILITY**. Derailleur-chain service includes length inspection, wear identification, removal, cleaning, sizing, lubrication, installation, and inspection of chains. **NON-DERAILLEUR CHAINS** covers master links and tensioning of chains. Information about rivets, cleaning, and lubrication of non-derailleur chains is the same as derailleur chains, so it is not repeated.

## DERAILLEUR-CHAIN SERVICE

### CHAIN-LENGTH INSPECTION AND WEAR IDENTIFICATION

It is a good idea to inspect whether the length of the chain is correct before removing it (for cleaning or other service). If during the service it is determined that a new chain is needed, then there is no need to go

through the process of determining the size by testing. If the old chain was the correct size, the new chain can just be cut to match. New chains all come in one uniform length which is long enough for all bikes, and usually must be sized to fit.

### *Length inspection*

1. [ ] **Shift chain onto outermost chainring in front and outermost cog in rear.**

There are several legitimate methods to determine whether a chain is an acceptable length. The method here is universal and should always get a close enough result. “Perfect” length is when in the specified gear combination, and with the bike at the angle it would be in if on level ground, the line through the center of both the rear derailleur pulley wheels is perpendicular to the ground. It is not necessary or always possible that the length be perfect, and in most cases, it is acceptable if the chain is up to one inch shorter or longer than perfect. If it is not possible to get the chain length close to perfect, then it is necessary to test for unacceptable chain length. If the chain cannot be sized to pass both the too-long and too-short tests, it means that the gear combination of the front chainrings and the rear cogs exceeds the maximum total capacity of the rear derailleur.

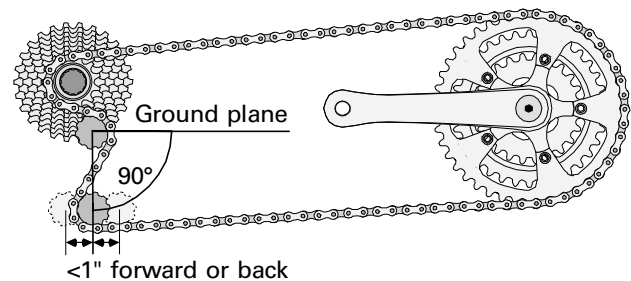

26.7 With the bike in the “on-ground” position, and with the chain in the outermost position front and rear, this is the alignment of the two rear derailleur pulley wheels when the chain length is perfect.

It is not unusual for bike manufacturers to supply a bike with a derailleur that does not have the proper capacity for the gears that come on the bike, particularly on high-performance mountain bikes. The customer may also elect to install a rear derailleur that does not have the capacity for all possible gear combinations. If the customer is aware of the limitations of running a chain that is too short or too long and can limit gear selection to avoid the consequences, then the customer may choose to keep a chain that is the wrong length. If the chain is left too long, that means that when the chain is on the smaller chainring it will be slack on one or more of the outermost rear cogs. If these combinations are avoided, there will be no prob-

lem. If the customer rides with the chain slack, there is a chance it will come off, or possibly come out of position in a way that it will jam in the rear derailleur and damage the rear derailleur. However, too long is a better choice than too short.

If the chain is left too short, it can have two consequences. It can reduce shift performance of the rear derailleur, particularly when on the large chainring and shifting onto one of the innermost rear cogs. The circumstance that the customer must avoid *at all times* is shifting into a large chainring/large rear cog combination that exceeds the capacity of the derailleur. The consequence is that the derailleurs can jam so badly that they cannot shift out of the unacceptable gear combination, or worse yet, the rear derailleur can be destroyed.

In step #2, the bike must be in the position that it is in when both wheels are on and the bike is on level ground. If the bike is in a stand and the top tube of the frame is not sloped, then simply level the top tube. If the top tube is not known to be level, adjust the angle of the bike so that both hub axles end up equidistant from the ground.

2. With bike in the “on ground” position, put a straight edge against center of rear derailleur’s upper pulley wheel, so that straight edge is perpendicular to ground, and check one of following options:

- Center of lower pulley wheel is  $\leq 1$ " in front of or behind straight edge, chain length appears acceptable.
- Center of lower pulley wheel is  $> 1$ " in front of straight edge, go to step 3 to check for chain too short.
- Center of lower pulley wheel is  $< 1$ " behind straight edge, go to step 4 to check for chain too long.

3. To check for chain too short:

- With chain on outermost chainring, shift chain to innermost rear cog.
- Check whether chain bends twice passing through rear derailleur cage. If not, chain is **too short** (circle if so).

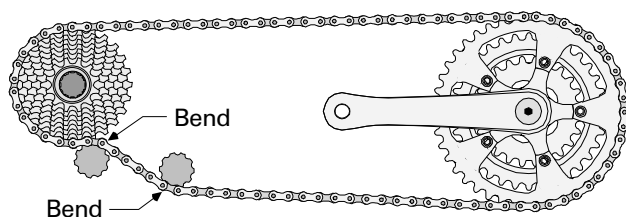

26.8 With the chain on the innermost rear cog and outermost chainring, this is what the chain and rear derailleur will look like if the chain is not too short. The chain must bend past each pulley wheel.

4. To check for chain too long:

- With chain on outermost rear cog, shift derailleur to put chain on innermost chainring.
- Check whether chain hangs slack between top of rear cog and top of chainring. If it does, chain is **too long** (circle if so).
- Check whether chain contacts itself or any part of rear derailleur after leaving bottom side of lower pulley wheel on way to bottom of chainring. If it does, chain is **too long** (circle if so).

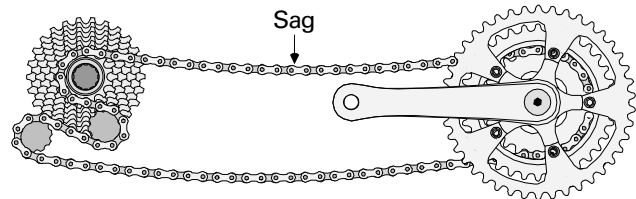

26.9 With the chain on the outermost rear cog and the innermost chainring, this is what the chain will look like if it is too long, in some cases. Note that the top section of chain is dangling.

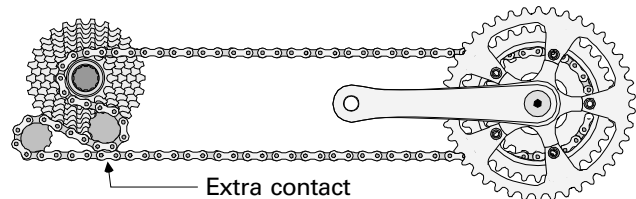

26.10 With the chain on the outermost rear cog and the innermost chainring, this is what the chain will look like if it is too long, in some cases. Note that the chain touches itself under the upper pulley wheel.

### Wear inspection

5.  Place Park CC-2 on top of chain with both pegs on underside of tool inside of a link. Gauge should be on left end of tool.
6.  Push gauge up as far as it will comfortably go and inspect whether both pegs are pressing against rollers and not against the end of an inner side-plate.
7. Read number on gauge in window of tool and check one of following options:
  - Reading 0 – .5, chain is fresh.
  - Reading .5 – < .75, chain is medium worn.
  - Reading .75 – < 1.0, chain is highly worn.
  - Reading 1.0, chain is worn out.

### CHAIN REMOVAL

8.  Spin chain-tool shaft to check whether rivet-driving pin of tool is bent.
9.  Shift chain to smallest chainring and smallest rear cog to reduce tension on chain.

## 26 – CHAINS

The biggest problem mechanics have with chain-  
rivet extraction is not making sure the chain is in the  
tool correctly before beginning the rivet extraction. The  
chain must be in the tool cradle completely, so that it  
does not shift around under load. The driving pin of  
the tool must be straight and centered on the chain rivet.  
Although this procedure requires high force in some  
cases, *be sensitive* and stop if it seems excessive. If  
the force does seem excessive, stop and double check every-  
thing. Failure to exercise proper care will result in the  
destruction of a chain link and/or the chain tool.

On certain chains, not all rivets are removable. In  
these cases, attempting to remove the wrong rivet can  
lead to chain failure. In general, any rivet that is double-  
peened is removable. Shimano Hyperglide/IG chains  
feature special replacement rivets (no double-peening)  
*that must not be removed*. The Sedis ATB chain fea-  
tures a single black half-link that includes *the only rivet  
that should be displaced and reinstalled*, but any rivet  
other than this special rivet should be removed to  
shorten the chain. There are other lesser-known chains  
that can have special rivets, so check any literature that  
comes with a chain for this information.

Some chain tools have two cradles on which to  
seat the chain. One of these cradles is for rivet removal  
and installation and the other is for eliminating tight  
links. If the wrong cradle is used, it will damage the  
chain and the tool. In all cases where there are two  
cradles, the one furthest from the rotating tool handle  
is for rivet removal and installation.

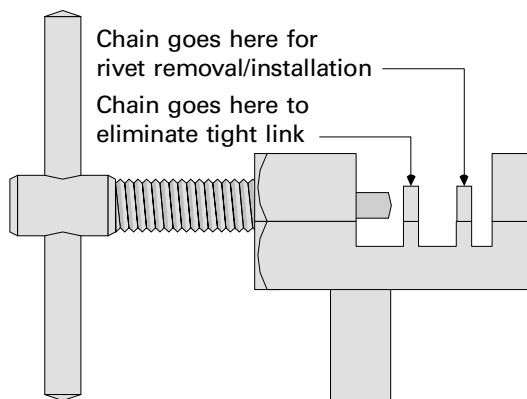

26.11 This is a side view of a chain tool with two cradles. Note which one is for rivet removal and installation.

10. [ ] Engage tool to lower section of chain and turn handle just until tool pin contacts chain rivet and make sure that tool pin is centered on chain rivet and that chain rollers are seated fully in cradle in chain tool.

In the next step, push a chain rivet *partially* out. A common mistake is too push it too far, which causes all kinds of trouble. It is better to push it too little than too much. The correct amount to push the rivet is so that the end being pushed clears the first outer side-plate, the first inner side-plate, the roller, and no more than half the second inner side-plate. When the links are separated, the rivet should be left protruding about .5mm to 1.0mm in the inner face of the second outer side-plate. This protrusion is used to hold the links together temporarily when sizing the chain, or when preparing to drive the rivet back in. Even with Hyperglide chains, with which the rivet is eventually replaced, it is an advantage to leave the rivet protruding in this fashion.

Most chain tools have a thread pitch on the tool shaft of 1mm. By counting the half-turns of the tool handle from the point it begins to push on the rivet, it is possible to control the amount that the rivet is pushed. Before starting the rivet extraction, measure the rivet length to determine whether the chain is a narrow or wide chain. If the handle is turned ten half-turns, it should push the rivet out just enough for a narrow chain. Eleven half-turns should be the correct amount for wide chains. It would not be a bad policy to stop a half-turn early and attempt to separate the links. Only if they are too difficult to separate should the rivet be pushed out 1/2 turn more. To separate the links, flex them sideways while pulling them apart.

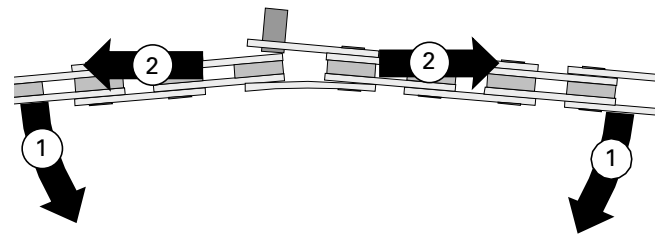

26.12 When the rivet is pushed out enough, flex the chain in this direction while pulling to get the links to separate.

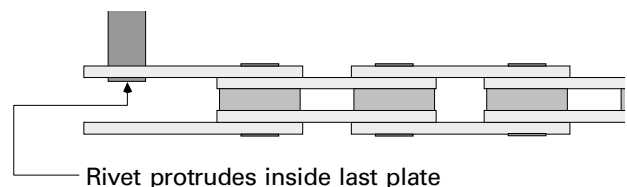

26.13 Once the links are separated, the rivet will protrude inside the outer side-plate if it was pushed out the correct amount.

11. [ ] **Note starting position of tool handle and turn handle appropriate number of turns to drive rivet through 2-1/2 side-plates. (If tool shaft has normal 1mm pitch, for narrow chains turn handle 10 half-turns, wide chains 11 half-turns. Park CT-3 has circlip on tool shaft to stop rivet removal at correct point.)**
12. [ ] **Loosen tool shaft until pin is out of chain and disengage tool from chain.**
13. [ ] **Flex chain laterally while pulling both directions from link with pushed-out rivet to complete separation of chain.**
14. [ ] **Pull on end of chain with protruding rivet to remove chain from bike.**

## CHAIN CLEANING

15. [ ] **To control chain properly while cleaning, fold chain in half and coil with loose ends at center of coil.**

If a chain is neatly coiled and contained in a container that is correctly sized to prevent uncoiling, then the chain is much less likely to end up tangled. A short can that has a diameter of 4.5–5.0 inches should fit most chains. A typical half-pound peanut can is just the right size.

16. [ ] **Submerge chain in can of solvent and let soak as long as possible.**
17. [ ] **Drain off solvent until chain is only slightly submerged, but can be easily seen.**

If a chain has been dirty a long time, then it may not be possible to clean it thoroughly. Clumps of hard dirt that cannot be dislodged by a stiff-bristle brush develop on parts of the link where metal-to-metal contact does not normally occur. Do not worry too much about removing this kind of dirt. The Park GSC-1 is a good brush for this purpose, which is also a recommended tool for freewheel cleaning.

18. [ ] **Use stiff-bristle brush to clean side of chain that is facing up.**
19. [ ] **Turn chain coil over and scrub second face in a similar fashion.**

The most important part of the chain to clean is the rollers. The chain must be uncoiled to access the rollers and laid out full length, or folded in half. It will not be possible to contain it in a container of solvent when it is extended in this fashion. If not using a full-size solvent tank, spread out several thick sections of newspaper on a large work surface big enough to cover the length of the entire chain. Make sure that the newspaper is thick enough to absorb all the solvent, or put a layer of plastic under the newspaper. The left-over sol-

vent from the side-plate cleaning may be enough to use while scrubbing the rollers, but periodically refresh the scrub brush in fresh solvent, if necessary.

20. [ ] **Remove and uncoil chain put it on its edge (rollers visible from directly above).**
21. [ ] **Use stiff-bristle brush to scrub rollers and inside of inner side-plates, periodically dipping brush in fresh solvent.**
22. [ ] **Turn chain over and scrub other edge in same fashion.**

Scrubbing the side-plates and the rollers does not remove the dirt from the chain, it has merely dislodged it. In the next step, rinse the chain repeatedly to get the dislodged dirt out of and off of the chain.

23. [ ] **Rinse chain thoroughly in fresh solvent.**

It is very important that the chain be *totally* dry before lubricating it. If solvent is inside the rollers when oil is added, then the solvent will displace or break-down the oil and the most important part of the chain to be lubricated will not be lubricated. If using compressed air for the drying, blow air over the entire chain on both edges and both faces repeatedly until there is no solvent creeping out from the overlapping side-plates or from between the rollers and the inner side-plates. If not using compressed air, it is difficult to know when the chain is dry, because the last and most critical part to dry is inside the rollers. Experience has shown that two hours in the direct sun on a warm day should be adequate, or 24 hours otherwise. Do not use application of heat to evaporate solvent because of the risk of fire and of the possible generation of toxic fumes.

24. [ ] **Use compressed air to dry chain *completely* (or 2 hours in direct sun, or 24 hours without direct sun or compressed air).**

## CHAIN LUBRICATION

There is probably more voodoo about chain lubrication than there is about any other subject regarding bicycle mechanics. The function of chain lubrication is actually very simple. The lubricant must remain between the moving parts to reduce friction and to keep rust from developing where moving parts touch each other, and it must remain as clean as possible because the contaminants create friction. The loads on bicycle chains are not so unusual that exotic lubricants are required to reduce wear and friction. If an exotic oil with outstanding friction-reducing properties evaporated or broke down quickly, or promoted the accumulation of dirt, then it would not be a better lubricant for a chain.

## 26 – CHAINS

There are two important properties to chain lubricants: they must minimize the accumulation of dirt, because dirt accelerates wear and chain cleaning is a hassle; they must also be durable, because lack of lubricant increases chain wear. Durability is the less significant factor because it is relatively easy to repeatedly lubricate a chain. In general, oils that are marketed specifically as bicycle-chain lubricants are going to be superior to all non-bicycle-specific products, including those general household and handyman oils that are *also* recommended for bicycles.

One of the factors that promotes dirt accumulation is the quantity of oil on the chain. Avoid oiling too frequently. Oil only when there is need. Avoid using certain aerosols, because they promote over-oiling. Always wipe off excess oil thoroughly with a clean rag.

Some aerosols are more of a problem than others. When considering some aerosol lubricants, perform a simple test. Squirt an equal quantity of each lubricant being considered on a clean, flat, metallic or glass surface. After 10 minutes, see if any of the lubricants have dried noticeably. This test simply identifies whether a lubricant has an evaporative base, or not. Those that stay wet are going to make the chain a gooey mess because the aerosol guarantees over application and the excess wet oil will be great at accumulating dirt. The same lubricant might be excellent in a drip container, because with a drip container it is possible to avoid over-application.

If the bike is ridden in conditions that expose the chain to water frequently, be concerned with whether the lubricant will wash off the chain too easily. A lubricant that does not hold up well to water will cause the chain to squeak within half an hour of riding after being in the rain. Historically, the lubricants that are best at remaining on after exposure to water are the worst about accumulating dirt. It may be best to compromise. Keep in mind that is always easier to add more lubricant (even in mid-ride) than it is to clean a chain.

When lubricating, there are four points at each rivet that need lubrication: between each overlap of an outer side-plate and an inner side-plate, and between the inner side-plates and each side of the roller. These are the four points where metal slides against metal. Oil is needed inside and on the surface of the rollers as well, but it will get there automatically when oiling each edge of the roller. The mistake is to think that the external surface of the chain needs oil. This just increases the mess and dirt accumulation. If using a spray lubricant, everything that needs lubrication will

get it in one quick pass of the nozzle over the chain. If using a drip lubricant, put a drip between each side-plate overlap and on each side of each roller.

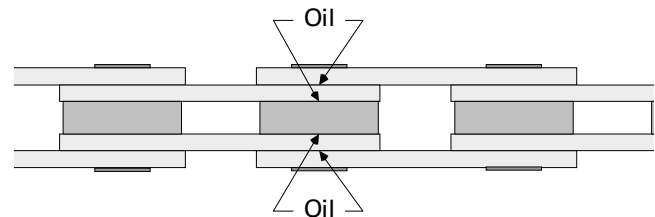

26.14 Lubricate each link at the four points shown.

25. [ ] Apply lubricant to chain so that it penetrates every overlap between an inner side-plate and an outer side-plate, and so that it penetrates between roller and where each roller contacts an inner side-plate.
26. [ ] If chain is installed, backpedal for 30 seconds, or if chain is off bike, wiggle it like snake for 30 seconds to help lubricant penetrate into crevasses.
27. [ ] Use clean rag (terry cloth preferred) to thoroughly wipe excess lubricant off of chain.

## CHAIN INSTALLATION

28. [ ] If replacing chain and existing chain was an acceptable length in step 2, remove links from new chain so that number of links in new chain matches number of links in old chain.
29. [ ] Position rear derailleur under outermost rear cog and front derailleur over innermost chainring.

When threading a chain through the derailleurs and around the gears, you will need to start with the end of the chain that has no rivet sticking out from a side-plate. Consider this the “no-rivet” end. It’s a handy technique to make sure that the rivet that is sticking out faces away from the bike once the chain is installed. This makes use of the chain tool less awkward.

Getting the chain correctly through the rear derailleur and around the gears can be confusing. Grab the end of the derailleur and rotate the cage until it is approximately straight up and down. See that the cage has a lower pulley wheel and an upper pulley wheel. The chain will go through the derailleur in a reverse “S,” and it will be fed from the bottom to the top. Once it has gone around the front and over the top of the upper pulley wheel, it goes up and around the back side of the outermost rear cog. When ready to put the no-rivet end through the front derailleur cage and around the large chainring, it is easiest if there is about

a foot of the end of the chain dangling from your fingertips to drop through the derailleur cage. Once it lands on the teeth, rotate the crank to pull the chain through.

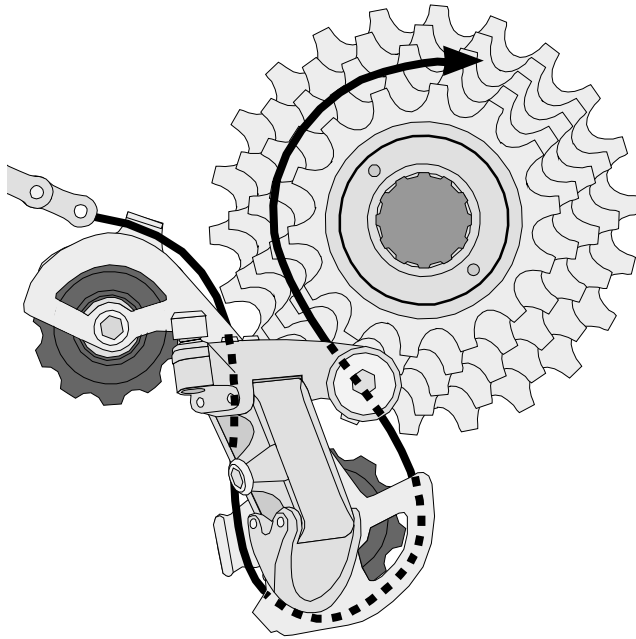

26.15 Follow the arrow to feed the chain through the rear derailleur and around the rear cog.

30. [ ] Feed no-riquet end of chain up around backside of lower rear derailleur pulley wheel, through derailleur cage, up and in front of upper pulley wheel, up and over backside of outermost rear cog, and down through front derailleur cage and onto innermost chainring (rotating crank to help pull chain through once chain falls on chainring teeth).
31. [ ] Join ends of chain temporarily together between bottom of chainring and rear derailleur by slipping end of chain with no rivet over rivet protrusion on other end of chain. (Inner half-link will be *outside* of an outer plate.)

## CHAIN SIZING

**NOTE:** If reinstalling an old chain that was an acceptable length and not installing a new chain, new rear derailleur, new-size chainrings, or new-size rear cogs, skip to **RIVET INSTALLATION**.

If chain length was not acceptable originally, then it is necessary to perform some tests to determine the best length. There is no standard number of links, formula, or table that can be used because there are too many variables. Chain length is set in a specific gear combination, with the chain on the outermost rear cog and innermost chainring. In this gear combination, if the chain is too long it will exhibit one of the

symptoms in figure 26.16. If one of these symptoms is exhibited, then adjust the length by one inch (two link) increments until the symptom just disappears.

Chain length is always important because it affects rear-derailleur shift performance. When there is a significant deviation from the recommended length, or when the rear-derailleur total capacity is being stretched to its limit, chain length is even more important because too short or long of a chain can lead to a damaged rear derailleur.

A common misconception about chain length is that it is adjusted to change the tension on the chain, particularly in the lower section of chain between the rear derailleur and the bottom of the chainrings. This is not adjustable, except by changing the rear derailleur's internal springs. The tension on the lower section of chain is also not of any great significance.

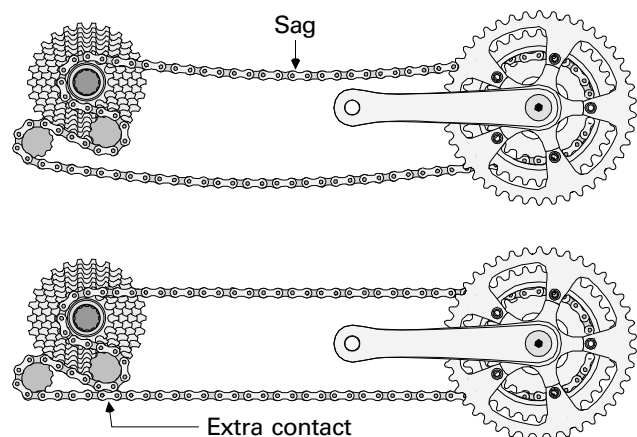

26.16 With the chain on the outermost rear cog and the innermost chainring, this is what the chain will look like if it is too long, in some cases. In the top example, note that the top section of chain noticeably sags. In the bottom example, note that the chain touches itself under the upper pulley wheel.

32. If existing chain is wrong length, or if replacing wrong-length chain with new chain:
- [ ] Inspect chain for sag in top section.
  - [ ] Inspect chain for extra contact at upper pulley wheel.
  - [ ] Adjust chain length one link at a time until sag or extra contact is just eliminated.

## RIVET INSTALLATION

**NOTE:** Steps 33–38 are for non-Hyperglide chains only. For Hyperglide/IG chains skip to Shimano HG/IG rivet installation.

### Non-Shimano HG/IG rivet installation

Before putting the chain on the chain tool to push in the rivet, join the ends of the chain together. If the rivet is protruding inside the outer side-plate, as it is supposed to, this can be awkward. Put the no-rivet end between the outer side-plates until it bumps into the protruding rivet. Use the no-rivet end as a lever to spread apart the outer side-plates, then force the no-rivet end past the protrusion of the rivet.

Mechanics get in trouble for several reasons when pressing in the rivet. First, they do not make sure that the holes in the four side-plates all line up before pushing in the rivet. This jams the rivet into the last side-plate it goes through and deforms the side-plate and bends the tool's driving pin. Second, they do not make sure that the chain is well seated in the tool cradle, so the rivet does not get pressed straight in, causing it to jam and damage the link or the tool. Finally, they do not make sure that the tool pin is straight and centered on the rivet, which causes the rivet to jam and damages the side-plates or the tool.

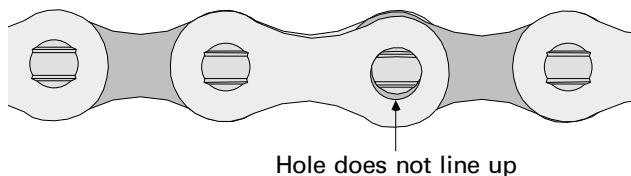

**26.17** This is what it looks like when the four side-plates do not line up.

Although high force may be required to push in the rivet, *be sensitive* to any excess force that indicates things are not lined up and the rivet is jamming.

Some chain tools have two cradles on which to seat the chain. One of these cradles is for rivet removal and installation and the other is for eliminating tight links. If using the wrong cradle, it can damage the chain and the tool. In all cases where there are two cradles, the one furthest from the rotating tool handle is for rivet removal and installation.

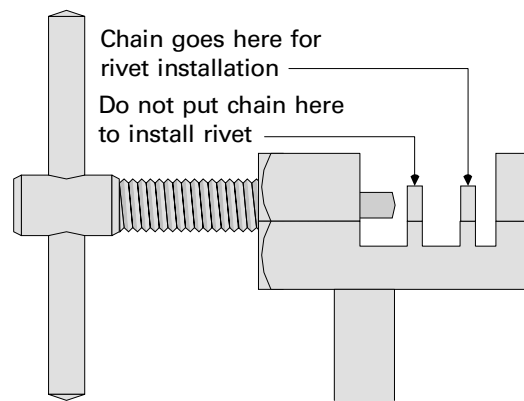

**26.18** This is a chain tool with two chain cradles. Put the chain on the cradle indicated when preparing to push in the rivet.

**33. [ ]** Join ends of chain together and put chain tool on chain so that rollers are fully down in cradle and turn tool shaft in until tool pin is just touching protruding end of chain rivet. Check that tool pin is centered on rivet.

**34. [ ]** Inspect that side-plates appear to be properly lined up.

When pressing in the rivet, look to see when to stop turning the tool handle. The objective is to end up with equal amounts of rivet protruding out past each outer side-plate. If the rivet is pushed too far, remove the chain tool and switch it to the other side.

**35. [ ]** Turn tool handle until same amount of rivet is showing outside each outer side-plate, being careful not to force rivet when side-plates are not properly lined up.

**36. [ ]** Loosen tool handle and remove tool from chain.

Pressing the rivet through all four side-plates at once causes the side-plates to compress against each other and pinch on the roller, which causes the link to be tight and hold a bend. Step #37 spreads the side-plates apart by flexing the chain laterally (perpendicular to the direction the links pivot). Chains are very strong, so do not be afraid to flex the chain vigorously.

If the flexing technique does not work, a chain tool is needed that has a tight-link-removal feature. This is always a tool that has two cradles on which to mount the chain. The one for tight-link removal is always the cradle that is closest to the rotating handle of the tool. When the chain is on this cradle, only the first two plates (closest to the tool pin) are supported by the tool. When the rivet is pressed further, it is moved further only through the first two side-plates. Since the rivet is moving through one outer plate, and is remaining unmoved in the other outer side-plate, the distance between the two outer side-

plates is increased. This eliminates the bind on the roller. A very little amount of displacement of the rivet is required to achieve this.

37. [ ] Pivot chain at rivet just installed and release slowly to see if chain holds bend.

38. If chain holds bend in previous step (tight link), perform these two steps (second one only if necessary):

[ ] Grasp chain firmly on both sides of tight link and flex chain vigorously side-to-side (at right angles to direction chain is meant to pivot) and test for tight link again.

[ ] If side flexing did not eliminate tight link, put chain on correct cradle of tight-rivet-removal tool, turn in tool shaft just until tool pin is firmly against rivet, turn tool 1/3 to 1/2 turn, and check again for tight link.

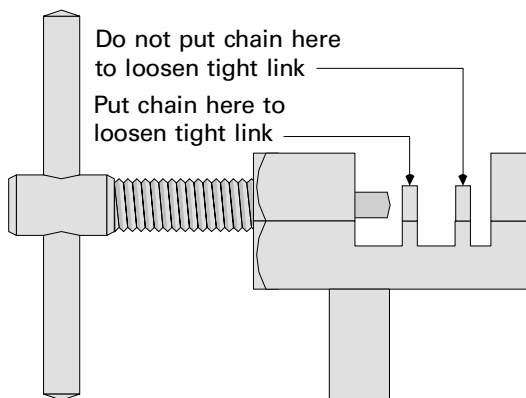

26.19 This is a chain tool with two chain cradles. Put the chain on the cradle indicated when preparing to loosen a tight rivet.

**NOTE:** Skip to CHAIN INSPECTION if not installing rivet in Hyperglide chain.

### Shimano HG/IG rivet installation

Hyperglide and IG replacement rivets require a great deal of force to install, and a great deal of resistance occurs at the final outer side-plate that the rivet goes into. If not done carefully, this procedure can easily damage the tool and the chain. Lubricating the rivet reduces the force required, which makes it easier to tell if something is jamming and actually reduces the amount of deformation of the outer side-plates that always occurs. A Hyperglide-compatible chain tool supports the outer side-plate in a way that reduces the deformation that occurs, as well.

The Hyperglide replacement rivet consists of two parts, a pilot shaft that has a tapered tip and a flare at the other end, and a flanged rivet that is a tighter fit than the rivet it replaces. The pilot shaft guides the rivet into place, expands the holes in the outer side-

plates to accommodate the larger rivet, and pushes the old rivet the rest of the way out. Once the replacement rivet is in place, the pilot shaft easily snaps off.

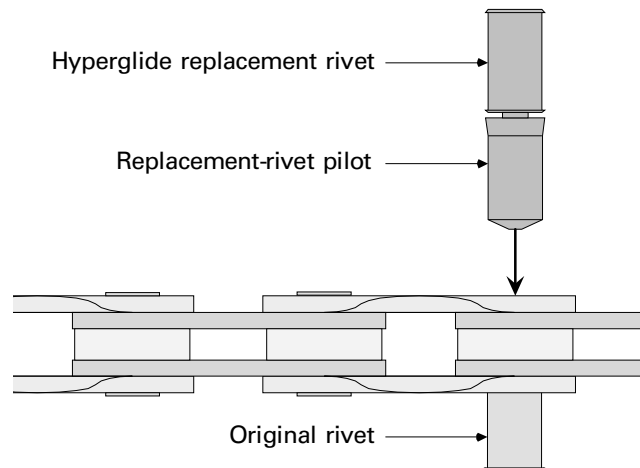

26.20 This is a Hyperglide replacement rivet.

39. [ ] Oil full length of Hyperglide replacement rivet.

40. [ ] Join ends of chain and insert tapered end of pilot shaft of Hyperglide replacement rivet through side-plates until replacement pilot shaft is butted against old rivet.

41. [ ] Put chain tool on chain so that rollers are fully down in cradles and turn tool shaft in until tool pin is just touching replacement rivet. Check that tool pin is centered on rivet.

As the leading end of the replacement rivet passes through each outer side-plate, there is more resistance than when the leading end of the replacement rivet is passing through the inner side-plates and the rollers (which have larger holes than the outer side-plates). When starting the replacement rivet in with the tool, expect an initial high resistance, followed by less resistance, and then an increase in resistance as the rivet begins to go through the final outer side-plate. When an equal amount of rivet protrudes from both outer side-plates, stop. However, stopping early will cause a tight rivet.

42. [ ] Turn tool handle until full length of replacement-rivet pilot shaft is exposed on far side of chain and equal amounts of replacement rivet are exposed outside both outer side-plates.

43. [ ] Loosen tool handle and remove tool from chain.

44. [ ] Use plier to grasp and snap off replacement rivet pilot shaft.

45. [ ] Pivot chain at rivet just installed and release slowly to see if chain holds bend.

A tight rivet on a Hyperglide chain is usually caused by incomplete installation of the replacement rivet. In any case, try side-flexing the chain first. If that does not work, use step #46 to center the rivet.

**46. [ ] Chain holds bend in previous step (tight link), perform these two steps (second one only if necessary):**

[ ] Grasp chain firmly on both sides of tight link and flex chain vigorously side-to-side (at right angles to direction chain is meant to pivot) and test for tight link again.

[ ] Inspect replacement rivet to see if either end is sticking out more than the other and put chain tool on to push that end of rivet further in.

## CHAIN INSPECTION

When finished with chain installation, check to make sure that everything has been done correctly, but also whether any previous work was done incorrectly. This inspection is a good idea, particularly for new bikes. Virtually 100% of chain failures can be attributed to improper installation of rivets. With proper inspection, about the only thing a customer will ever use a chain tool for when on a ride is fixing other people's chains.

**47. [ ] Inspect both outer side-plates where rivet was installed for deformation (bulging) around rivet hole or metal shards from fractured edge of rivet hole. Replace link if either problem is found.**

In step #32, when the chain was sized, it was set at the longest acceptable length. If there is a problem with derailleur capacity, or an error was made in sizing the chain, there is a possibility it is now too short. The next step tests for whether the chain is too short. If at its original length (as of completion of step #32) the chain was too short, then the maximum total capacity of the rear derailleur has been exceeded. Ideally, the derailleur or the size of the chainrings/rear-cogs should be changed. If this is not an option, reinstall a link and check again for symptoms of a short chain. Go back to the section **CHAIN SIZING** (page 26-11) to consider the implications of running a chain that is too short or too long.

**48. [ ] Put chain on innermost rear cog and outermost chainring and check whether chain bends twice as it passes through rear derailleur cage. If chain exhibits signs of being too short (not bending twice), and chain was too long when it was one link longer, it indicates maximum capacity of rear derailleur has been exceeded.**

**49. [ ] Inspect both faces of chain thoroughly for any rivet protruding significantly more than others and correct as necessary.**

**50. [ ] With chain on innermost chainring and outermost rear cog, rotate crank slowly backwards and look for tight links coming out of rear derailleur, and correct as necessary.**

## NON-DERAILLEUR CHAINS

### MASTER LINKS

With the exception of track bikes, virtually all bikes without derailleurs have a chain with a master link. Master links are occasionally used on derailleur chains.

Master links come in several varieties, although only two that are generally encountered. These are the clip-on variety and the snap-on variety.

#### Clip-on master links

The clip-on master link consists of three parts. One part is an outer plate with two rivets permanently fixed. Another part is an outer plate with two holes for rivets. The third part is an elongated circlip that clips into grooves in the ends of both rivets. See the following illustrations for removal and installation methods.

It is good practice (and makes for easier maintenance) to install the clip on the outer face of the chain, with the closed end of the clip pointing in the direction of the chain's rotation.

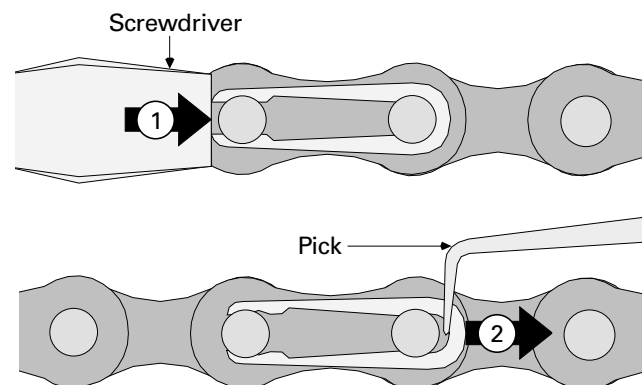

26.21 Removing the clip from a clip-on master link.

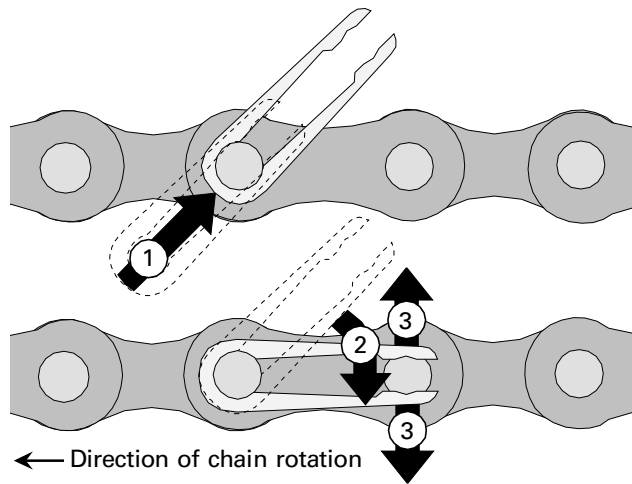
26.22 *Installing the clip on a clip-on master link.*

### Snap-on master links

The snap-on master link consists of two parts. One part is an outer plate with two rivets permanently fixed. The other part is an outer plate with two holes for rivets. The rivets on one outer plate have grooves that engage the holes in its counterpart. The rivets are fixed so that their ends are slightly farther apart than the holes in the outer plate. The plate with the rivets must be flexed to move the rivet ends close enough together to insert the rivets into the other plate. Once joined together, the outer plate with holes is trapped in the grooves in the rivets. Although this design has existed for decades on chains for non-derailleur bikes, a new version by Taya is available with dimensions that are compatible with derailleur chains. The Taya version differs in two minor respects other than dimension: the assistance of a screwdriver may be needed to pry the plates apart, and Taya is adamant that a link that has been removed should not be reinstalled.

It is good practice to install the plate with holes on the outer face of the chain.

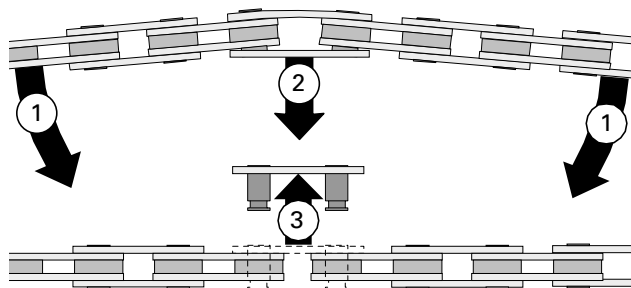
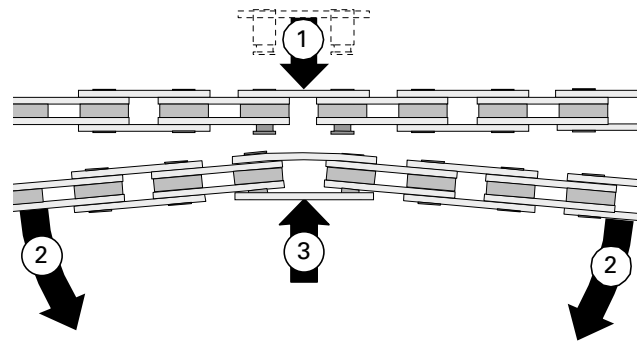
26.23 *Removing the snap-on master link.*26.24 *Installing snap-on master link.*

## CHAIN TENSION

If the chain tension is too tight, it will not operate smoothly. If it is too loose, it will fall off. Because gears are not perfectly round, chain tension will vary depending on the point of rotation of the crank. Find the point at which the chain is tightest and adjust the wheel forward or backward until the chain will move up and down 1/2" at the point halfway between the front and rear gears.

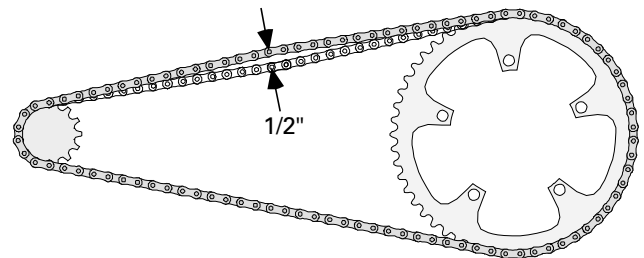
26.25 *Proper chain tension on a non-derailleur chain.*

## ***CHAIN TROUBLESHOOTING***

<b><i>Cause</i></b>	<b><i>Solution</i></b>
<b>SYMPTOM:</b> <i>Chain slips or skips on a cog when pedaling hard.</i>	
Fresh chain not meshing with worn cog.	Replace cog or cogs.
Worn chain not meshing with fresh cog(s).	Replace chain.
Pawls are not catching on internal ratchet ring because they are dirty, rusty, worn, or broken.	Clean and oil freewheel/freehub body and replace if symptom persists.
<b>SYMPTOM:</b> <i>The top section of chain hangs slack when the chain is on an outermost rear cog and the innermost chainring.</i>	
Chain is too long.	Put chain in correct gear and check chain length.
If chain length checked to be correct, rear-derailleur maximum total capacity has been exceeded.	Change gearing or derailleur to match capacity, or learn to ride with limits of a chain that is too long.
<b>SYMPTOM:</b> <i>The bottom section of chain touches itself or the derailleur cage just below the upper pulley wheel when the chain is on an outermost rear cog and the innermost chainring.</i>	
Chain is too long.	Put chain in correct gear and check chain length.
If chain length checked to be correct, rear-derailleur maximum total capacity has been exceeded.	Change gearing or derailleur to match capacity, or learn to ride with limits of a chain that is too long.
<b>SYMPTOM:</b> <i>The derailleur jams going on to or off of the innermost rear cog, only when the chain is already on the outermost chainring.</i>	
Chain is too short.	Put chain in correct gear and check chain length.
If chain length checked to be correct, rear-derailleur maximum total capacity has been exceeded.	Change gearing or derailleur to match capacity, or learn to ride with limits of a chain that's too short.
<b>SYMPTOM:</b> <i>The chain seems to skip or jump regularly, but at a cycle that is equal to once every several crank revolutions.</i>	
Tight link.	Rotate crank backwards and check for tight link where chain comes out of rear derailleur.
Protruding rivet on inner face of chain.	Inspect inner face of chain for rivet(s) protruding more than others.
Twisted side-plates from chain jamming during catastrophic over-shift off gears.	Replace chain.
<b>SYMPTOM:</b> <i>A tight link cannot be eliminated by the side-flexing technique or by using the tight-link-removal feature of the chain tool.</i>	
Chain is rusty, dirty, or needs lubrication.	Clean and oil chain. Replace if problem persists.
<b>SYMPTOM:</b> <i>A rivet has come out and the link has blown apart while riding the bike.</i>	
Rivet was incompletely installed.	Replace link if chain new, otherwise replace chain.
A pebble or other small hard object was jammed inside the link with the gear tooth and spread the outer side-plates too far apart.	Replace link if chain is new, otherwise replace chain.
<b>SYMPTOM:</b> <i>Chain seems to rub against next cog inward in most or all gears.</i>	
Wide chain is being used with narrow-spaced rear cogs if symptom happens in most gears.	Replace chain with narrow chain.
Spacing is wrong between two cogs, particularly if symptom only happens in one gear and cogs have recently been removed and re-installed from freewheel/freehub body.	Check and correct spacers between cogs.

<b>Cause</b>	<b>Solution</b>
<b>SYMPTOM:</b> <i>Chain doesn't squeak but seems to be noisier after cleaning than before.</i>	
Excessively dirty, gummy chain was muffling normal chain noise.	Start worrying when it gets quiet again, and then clean it again.
<b>SYMPTOM:</b> <i>Chain makes a regular chirping or squeaking sound after being cleaned and oiled.</i>	
Certain links were not oiled.	Back pedal slowly and stop as soon as chirping occurs. Un-oiled link is now in rear-derailleur cage or has just moved out of the rear-derailleur cage.
Chain was not thoroughly dried of solvent and solvent is displacing or breaking down lubricant in certain links.	Back pedal slowly and stop as soon as chirping occurs. Noisy link is now in rear-derailleur cage or has just moved out of the rear-derailleur cage. Flood offending link with lubricant. If this fails, remove and clean chain again and dry thoroughly.
<b>SYMPTOM:</b> <i>Chain seems to stick to inner chainring and does not release to go to rear derailleur, then jams between chainring and chain stay.</i>	
Chain or chainring is fouled with dirt.	Clean chain and chainring.
Chainring is worn out and has hooked teeth.	Replace chainring (steel preferred).
Thick aluminum chainring is intolerant of certain chains.	Replace inner chainring with narrow-steel model.

## ***EIGHT- AND NINE-SPEED COMPATIBILITY***

### **DIMENSIONS**

Nine-speed chains are technically  $1/2" \times 3/32"$  chains, just like all other derailleur chains. Even before nine-speed chains were introduced, the dimensions for derailleur chains in this size category varied (see **CHAIN DIMENSIONS AND TYPES**, page 26-2), but the variations were small enough that all chains still fit on most cogs and chainrings. The nine-speed chain has an outside width of approximately 6.6–6.8mm, .5mm less than any other type of chain. This narrower width allows the cogs on a nine-speed rear cog set to be spaced much closer together, so that the nine cogs fit in almost the same total space as eight cogs.

### **COMPATIBILITY**

The nine-speed chain is still close enough to the dimensions of other derailleur chains that it fits eight-speed and lesser configurations. However, the lesser spacing between cogs on nine-speed cog sets makes it impossible to use anything other than a nine-speed chain on nine-speed cog sets.

Shimano nine-speed drive trains have other differences in addition to the chain and spacing between cogs. Spacing between chainrings has been reduced, and the width of the front derailleur cage has been reduced as well. As a result, chains that are not the nine-speed dimension are not compatible with chainrings and front derailleurs that are designated as nine-speed configurations.

The nine-speed chain can be used with other than nine-speed chainrings and front derailleurs. Due to design differences more than dimension differences, performance might be slightly compromised, but this combination will be functional.

At the time of this writing, Shimano nine-speed chains have a different design from their previous chains, not just different dimensions. Most current Shimano chains that are not nine-speed type are the IG design. This design has side-plate shaping that is designed to optimize shifting from smaller to larger-diameter gears and additional shaping that is designed to optimize shifting from larger to smaller-diameter gears. The nine-speed chain is an HG design, which only has the shaping designed to optimize shifting from smaller to larger-diameter gears. Consequently, the

nine-speed chain, whether used on a nine-speed drive train or a drive train that is other than nine-speed, will not shift as well from larger to smaller-diameter gears (particularly under high load).