

22 – ONE-PIECE CRANKS

ABOUT THIS CHAPTER

This chapter is about a type of crankset called a one-piece crank. The name comes from the fact that the crank arms and the bottom-bracket spindle are all integrated into one piece. Consequently, crank-arm removal and bottom-bracket-bearing service are all one operation.

These cranksets are found on many types of bikes with one common characteristic: low cost. Most department store models, including derailleur and non-derailleur types, have this crank style. Almost all BMX bikes of any quality do, also. Older Schwinn's of all types and virtually all single-speed coaster brake bikes have this crank style.

One of the few virtues of this crank style is that it uses a universal bottom-bracket shell. No matter what the brand, bike type, or vintage, a new complete crankset can always be installed.

GENERAL INFORMATION

TERMINOLOGY

One-piece crank(set): A crankset that has one continuous piece of metal that forms both the left and right crank arms and the bottom-bracket spindle.

Pressed cups: Bearing cups that press into the bottom-bracket shell.

Crank arm: The arm to which the pedal attaches.

Arm set: The piece that includes both crank arms and the bottom-bracket spindle.

Bottom bracket: The bearing assembly about which the crank arms rotate, installed in the bottom-bracket shell.

Bottom-bracket shell: The cylindrical shell at the bottom of the frame into which the crankset bearings are installed.

Fixed cone: A bearing cone that is fixed in position. The fixed cone is threaded onto the left end of the spindle-portion of the crank-arm set.

Adjustable cone: A bearing cone that has an adjustable position. The adjustable cone is threaded onto the left end of the spindle-portion of the crank-arm set.

Locknut: A nut that is threaded against the adjustable cone to secure its position.

Lock washer: A keyed washer that goes between the locknut and the adjustable cone so that one can be turned without affecting the position of the other.

Bearing retainer: A circular clip filled with ball bearings. Also called simply a “retainer.”

Spider: A structure that mounts to the crank arm behind the fixed cone to which the chainring attaches. It originally consisted of five arms, hence the name “spider.” These days, the spider is often a disc.

Chainring: A disc or ring with teeth at the outer perimeter that mounts to the spider or directly to the crank arm behind the fixed cone.

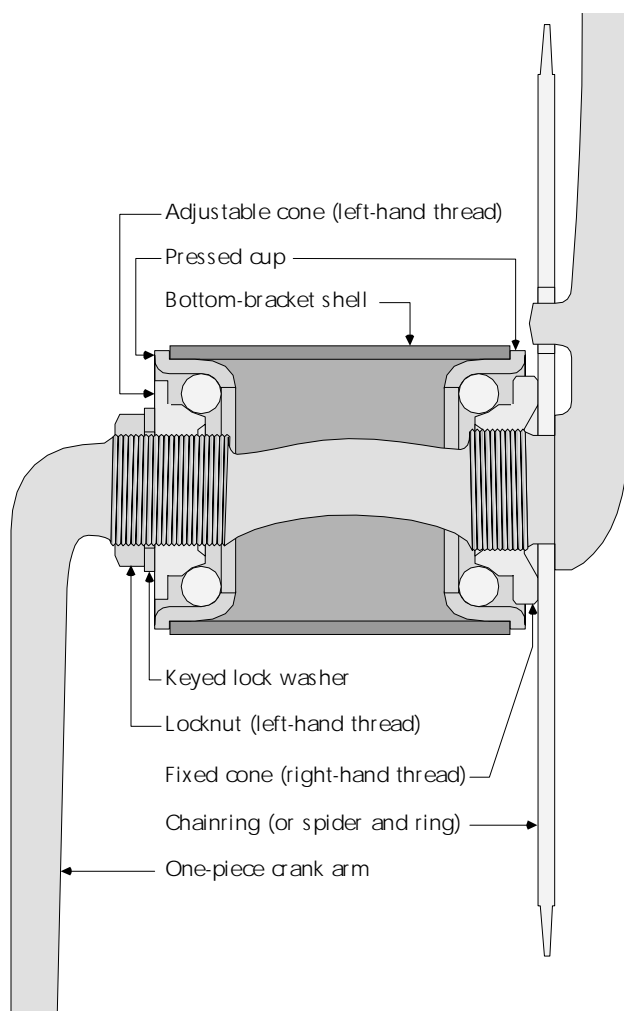

22.1 Parts on a one-piece crankset.

PREREQUISITES

The only prerequisites for servicing one-piece cranks are the ability to remove and install pedals and the rear wheel.

INDICATIONS

Maintenance cycles

Due to the soft metal that is used in all brands and models of these cranks and the exposed nature of the bearings, adjustment and overhaul of these bearings is required much more frequently than with adjustable-cup bottom brackets. Its likely that anytime a bike with this type of equipment comes into the shop, the bearings will be in need of some sort of service. It is unlikely that the typical owner of a bike with this equipment is going to be willing to have a shop service the bearings as often as the bearings need it. Consequently, the shop is often forced to leave problematic one-piece-crank bearings alone, or is left with no choice but to make less-than-satisfactory adjustments to worn-out and dirty equipment.

Symptoms indicating bearings need adjustment

If play is felt at the ends of the crank arms, adjustment is needed. Since the bearings lack precision and the arms cannot be removed from the spindle, over-tight adjustments are harder to detect. With the chain removed from the chainring, a good shove should spin the crankset around several revolutions. If it stops quickly, the bearings should be adjusted.

Symptoms indicating bearings need overhaul

When play has been eliminated, if the crank does not spin for several revolutions after a good shove with the chain off the rings, then the bearings are due for overhaul.

Symptoms indicating need of arm-set replacement or repair

Crank arms bend frequently on these cranks.

If they are bent from abusive jumping, either of the two following symptoms might be immediately apparent: 1) crank arms that are no longer 180° apart, 2) chainrings that appear to oscillate as they rotate. If the crank-arm set is bent in the spindle portion, upon further inspection it is likely to be found that the bearing adjustment becomes too tight at the point free-play is eliminated, or that the faces of the cones will appear to oscillate as the crank turns (certain proof of a bent spindle-portion). If further inspection shows that the cones and cups are not worn out, then the tight-adjustment problem is caused by the spindle portion of the crank-arm set being bent. In all cases the crank-arm set must be replaced.

When the bike falls over, a crank arm may bend in on one side. Oscillating will be felt in the ankle on that side when the bike is ridden. It could also be a bent pedal shaft. A bent crank arm can sometimes be repaired. It is repaired on the bike using the Park HSC-1.

Stripped pedal-mounting threads cannot be repaired by using a thread-bushing (as is the case with other cranks, see page 24-6) due to the thin amount of material around the hole. The arm set must be replaced.

Symptoms indicating need of chainring replacement

Single chainrings rarely need to be replaced because, if bent, they can be bent back with great success. They do not need to be very straight to work, since there is no shifting or front derailleur.

Multiple chainrings usually need to be replaced when they wobble. Precision repair is difficult, but true chainrings are critical to derailleur performance.

ONE-PIECE-CRANKSET TOOLS (table 22-1)

Tool	Fits and considerations
LOCKNUT, ADJUSTABLE-CONE, and FIXED-CONE WRENCHES	
Diamond C79	Old-fashioned monkey wrench fits odd-size fixed cones not fit by fixed-cone spanners and all sizes of locknuts (special order from Ace hardware stores)
Park HCW-1	26mm open end for locknut, some adjustable cones, and 43mm for fixed cone
Park SPA-4	Fits slots in face of some adjustable cones
Hozan C205	Hook spanner fits some fixed cones
CUP PRESS	
Bicycle Research CP1	Fits bottom-bracket pressed cups and BMX headset cups
Park HHP-1	Expensive, fits bottom-bracket pressed cups and BMX headset cups

TOOL CHOICES

The design or brand of bottom bracket will determine the tools needed. Table 22-1 (page 22-2) covers tools for one-piece bottom brackets only. This list covers all the tools for the job. The preferred choices are in **bold**. A tool is preferred because of a balance among: ease of use, quality, versatility, and economy. When more than one tool for one function is in **bold**, it means that several tools are required for different configurations of parts.

TIME AND DIFFICULTY

Adjustment of a one-piece-crank bearing is a 2–5 minute job of little difficulty.

Overhaul of the bearings, replacement of the arm set, or replacement of the spider/chainring is a 30–35 minute job of little difficulty.

COMPLICATIONS

Left-hand threads

The locknut and adjustable cone on the left side of the bike are left-hand threaded. This is the opposite of the thread direction on the left side of a adjustable-cup bottom bracket. A mechanic's first few encounters with a one-piece crank are confused by this need to turn all the left-side parts the opposite direction of normal.

Stripped key on lock washer

Many bottom brackets do not allow simultaneous use of a tool on the locknut and adjustable cone. The design relies on the lock washer to keep the adjustable cone from rotating when the locknut is being broken loose or secured. When the washer fails during locknut removal, the cone and locknut rotate together and never break loose from each other. Persistent high force is required to turn the locknut until it is all the way off the threads.

If the lock washer fails while securing the locknut, the adjustable cone will turn and tighten up the bearings until the crank will not rotate. If this is detected early, the locknut is usually not very tight against the cone, and can easily be threaded off so that the lock washer can be replaced.

Non-compatible retainers

There are two sizes of retainers used in this type of crank. They are called #64 and #66, and are not easily distinguished by sight. They fit inside cups that are slightly different in size inside, but are not marked differently in any way. The #66 retainer snaps into a cup made for a #64 retainer.

The problem that results from using a #66 retainer in the wrong cup will be experienced *only while disassembling*. Since there is no good way to grasp a retainer and pull it out of a cup, it is essential that the retainer be a loose fit in the cup, so that it can fall out on its own once the cone is out of the way. The #66 retainer in a wrong-size cup is too tight a fit to fall out. In this case, the retainer must be mangled and pried out before the arm set can be removed.

Two thread types

The arm set and cones are either threaded 24tpi or 28tpi. There are no simple guidelines about when a specific pitch might be encountered. The simplest approach is to always replace complete bearing sets, and to select one that matches the pitch of the arm set.

Difficult pressed-up installation

There is officially only one dimension for the fit of the pressed cups to the bottom-bracket shell, but sometimes it will seem as though the cups must be the wrong size because they are so difficult to install. This is usually in chromed frames and is due to thick layers of chrome. The best solution is to grease the cups (not normally done), use a press tool made specifically for these cups (see table 22-1, page 22-2), and just use whatever force is necessary.

Loose pressed cups

Extremely loose cups cause mysterious knocking sounds while riding the bike. Marginally loose cups will creak. There are not different sizes available to improve fit to the shell. Use Loctite RC680 to improve fit.

Primitive adjustment

The adjustment of these bearings is primitive because the precision of the parts is poor and because the control over the adjustable cone while securing the locknut is sometimes limited. Do not apply conventional standards to what a “good” adjustment is. Of course, there should be no free play in the finished adjustment. If the crank spins a few times once play has been eliminated, consider the adjustment good.

ABOUT THE REST OF THIS CHAPTER

The rest of this chapter is divided into two sections, **OVERHAUL AND REPLACEMENT** and **ONE-PIECE-CRANKSET TROUBLESHOOTING**.

If you are just adjusting the bearings, go to the section of **OVERHAUL AND REPLACEMENT** titled **BEARING ADJUSTMENT** (page 22-6).

OVERHAUL AND REPLACEMENT

PREPARATIONS

1. [] Remove left pedal.
2. [] Only if replacing arm set, remove right pedal.
3. [] Move rear wheel to create chain slack, and drop chain off of chainring.
4. [] Inspect for arms not 180° apart.
5. Spin crank and look for (check all that apply):
 - [] bent chainring
 - [] oscillating chainrings/spider
 - [] oscillating cone faces

DISASSEMBLY

Arm-set removal

6. [] Turn locknut clockwise to break loose and thread fully off.

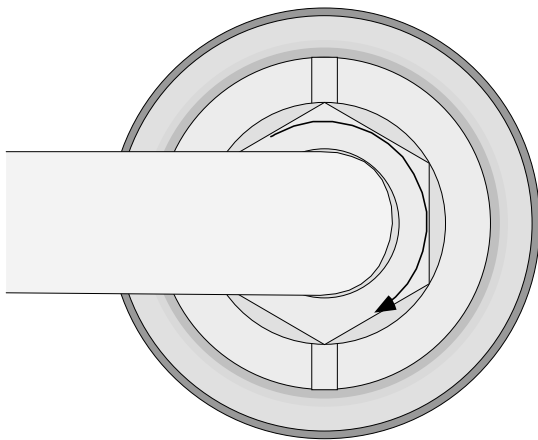

22.2 Turn locknut clockwise to remove.

7. [] Remove lock washer.
8. [] Turn adjustable cone clockwise to unthread fully.
9. [] Pull retainer out of left cup.
10. [] Shift crankset to right and drop retainer out of right cup and onto spindle.
11. [] Snake crankset out right side of bottom-bracket shell.

Inspection

As in all other bottom brackets, cones and cups wear by pitting. In addition, the cups may have cracks at the inner edge, indicating over-tight bearing adjustment (all the way around), or jumping abuse (bottom half only).

The lock washer has a key on the inner perimeter. This key is critical to adjusting the bearings, so the lock washer should be replaced if the key is deformed in any way.

12. [] Inspect cones, cups, and lock washer to determine wear and failure.

Bearing-set removal

NOTE: Skip step 13 if cups and cones were fine in inspection (step 12).

13. [] Use punch to drive both pressed cups out of shell.

NOTE: Skip step 14 if cups and cones were fine in inspection (step 12), and chainring/spider will not be replaced.

14. [] Secure right arm in soft jaws in vise with spindle portion of arm set facing up, and turn fixed cone counterclockwise to remove.

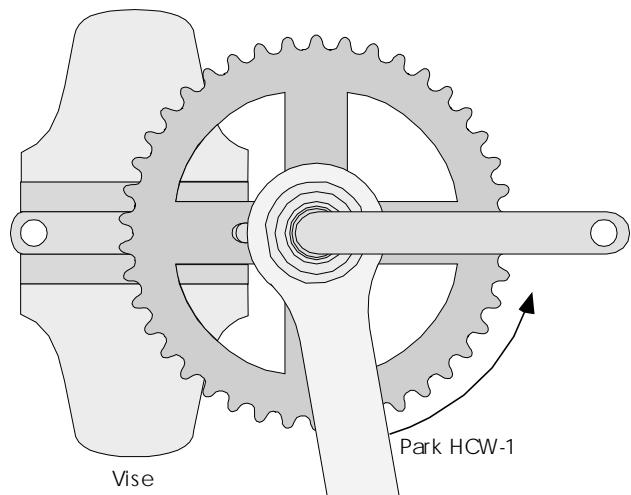

22.3 Removing the fixed cone.

Chainring/spider removal

NOTE: Skip step 15 if chainring/spider will not be replaced.

15. [] Noting direction it faces, lift chainring/spider off arm set.

CLEANING

16. [] Clean all parts thoroughly, including inside of shell (except retainers, which should always be replaced).

PARTS REPLACEMENT

Retainer replacement

Bearing retainers are usually marked “64” or “66.” If not marked, #64 retainers have nine balls and #66 retainers have 10 or more. If unsure which size is needed for existing cup, try pressing a #66 retainer into the cup. If it snaps in, the cup fits a #64. If it goes in effortlessly, the cup fits a #66 retainer.

17. [] Determine if existing retainers are #64 or #66 and find matching replacement.

Bottom-bracket replacement

It is not recommended to replace individual cups and cones due to limited parts availability and compatibility issues, as well as economy issues. Since the fit to the bottom-bracket shell is universal, the only critical thing to selecting a suitable replacement bearing set is the arm-set thread pitch, which could be 24tpi or 28tpi. Measure the pitch with a thread-pitch gauge.

18. [] Determine if existing arm set thread pitch is 24tpi or 28tpi and find matching bottom bracket.

Arm-set replacement

Arm sets vary in thread pitch and in arm length. Measure the pitch with a thread-pitch gauge. Arm length is measured from the center of the spindle axis to the center of the pedal-mounting hole. Arms come in 1/2" increments, so precision of measurement is not critical.

19. [] Determine if existing arm-set thread pitch is 24tpi or 28tpi and find matching arm set of same or preferred arm length.

Chainring/spider replacement

Chainrings and spiders can have different mounting-bolt patterns. Although almost all spiders and chainrings have five-bolt patterns, the hole-to-hole dimension of the chainring and mounting arms may vary (see page 23-6). If the number of bolt holes in the chainring and spider match, and hole-to-hole dimensions match, then two parts have the same bolt pattern.

All multiple chainring sets have a uniform tooth thickness, which fits only a 1/2" × 3/32" derailleur chain. Single chainrings could have a tooth thickness of approximately 2.2mm or approximately 2.7mm. The thinner teeth fit all chains, but the 2.7mm teeth fit 1/2" × 1/8" chains only.

If the number of teeth change when installing a new chainring, the chain length will need to be changed.

20. [] Determine chainring-bolt pattern and find matching chainring or spider (select one-piece chainring/spider) of suitable tooth number and tooth thickness.

ASSEMBLY

The pressed cups are kept in by friction. The mating surfaces should be cleaned with alcohol or acetone. If the cups are an extremely tight fit, or loose, there are exceptions. Extremely difficult to install cups should be greased. Loose cups should be installed with Loctite RC680.

21. [] Clean cups and shell with alcohol/acetone and use press to install cups fully in bottom-bracket shell.

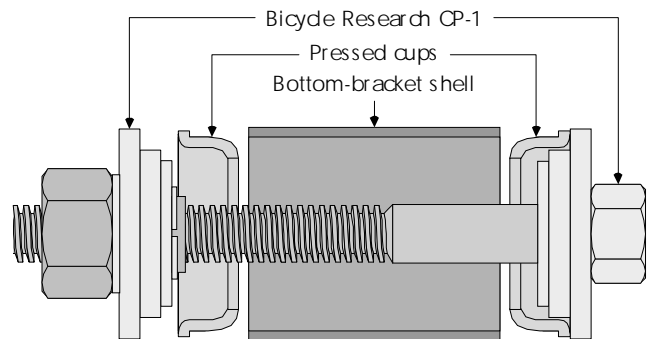

22.4 Setup for using the Bicycle Research CP1 to install the cups.

22. [] Secure right arm in soft jaws of vise with spindle portion of arm set pointing up.

Install chainring/spider

23. [] Place chainring/spider over left end of arm set and rotate to engage arm-set peg into chainring/spider hole.
24. [] Grease fixed cone threads.
25. [] Thread fixed cone on clockwise and secure to 300–350in-lbs (30–35lbs@8").

22 – ONE-PIECE CRANKS

Arm set installation

- 26. [] Put heavy coat of grease on fixed cone.
- 27. [] Place retainer (exposed-bearings-side up) on fixed cone and cover heavily with grease.

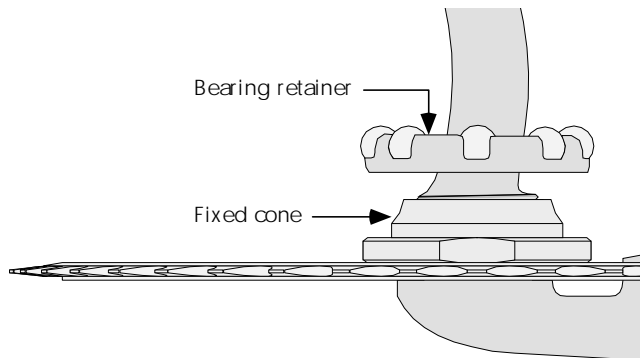

22.5 Place retainer on fixed cone.

- 28. [] Put heavy coat of grease on adjustable cone.
- 29. [] Place retainer (exposed-bearings-side up) on adjustable cone and cover heavily with grease.
- 30. [] Grease left-side threads on arm set.
- 31. [] Snake left end of arm set into right side of bottom-bracket shell until right-side retainer is inside of right cup.
- 32. [] Thread adjustable-cone/retainer assembly counterclockwise onto left threads of arm set.

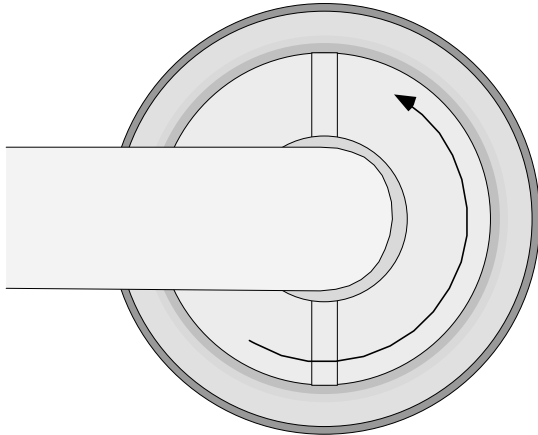

22.6 Thread adjustable cone on counterclockwise.

- 33. [] Slide lock washer onto left end of arm set.
- 34. [] Thread locknut counterclockwise onto left-side threads.

BEARING ADJUSTMENT

NOTE: If bearings were not just overhauled or installed, turn locknut clockwise to break loose and loosen adjustable cone before doing step 35.

- 35. [] Thread adjustable cone counterclockwise towards bearings until contact is just felt, then back off clockwise 90°.
- 36. [] Holding adjustable cone stationary if possible, secure locknut counterclockwise to approximately 300in-lbs (30lbs@10").
- 37. Jerk on ends of crank arms to feel for free play:
 - [] If none felt, redo step 35 even looser.
 - [] If play felt, proceed to next step.
- 38. [] Use marker to put matching marks at edge of cone and lip of cup.
- 39. [] Break loose locknut.
- 40. [] Rotate cone counterclockwise to put cone mark 5mm past cup mark and put new matching mark on cup lip.

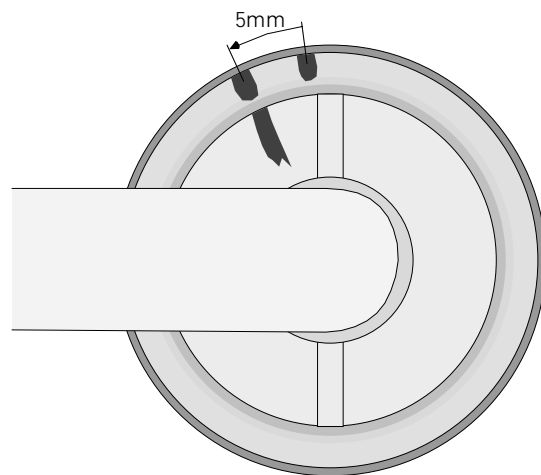

22.7 Cone moved to 5mm counterclockwise of original cup mark, and new mark added to cup.

When securing the locknut, the cone mark may shift counterclockwise from the new cup mark. If this happens once, it should happen the same every time. If this is the case, deliberately set the cone mark short of the new cup mark so that when the locknut is secured, the cone mark will shift to line up with the cup mark.

- 41. [] Holding adjustable cone stationary if possible, secure locknut counterclockwise to approximately 300in-lbs (30lbs@10").
- 42. Jerk on ends of crank arms to feel for free play:
 - [] If no play felt, adjustment is complete.
 - [] If play felt, repeat steps 39–42.

COMPLETION

- 43. [] Install pedal(s), if removed.
- 44. [] Mount chain on chainring.
- 45. [] Tension chain and secure rear wheel.