

# 21 – COTTERED CRANK ARMS

## ABOUT THIS CHAPTER

This chapter is about removing and installing cottered crank arms. There are different chapters for taper-fit crank arms (**20 – TAPER-FIT CRANK ARMS**) and for one-piece crank arms (**22 – ONE-PIECE CRANKS**). There is also a separate chapter (**23 – CHAINRINGS**), which should be referred to if the chainrings will be removed, replaced, or secured. There is also a separate chapter (**24 – PEDAL REMOVAL, REPLACEMENT, AND INSTALLATION**), which includes information about pedal removal and installation, a job that is often done as part of crank-arm removal and installation.

## GENERAL INFORMATION

### TERMINOLOGY

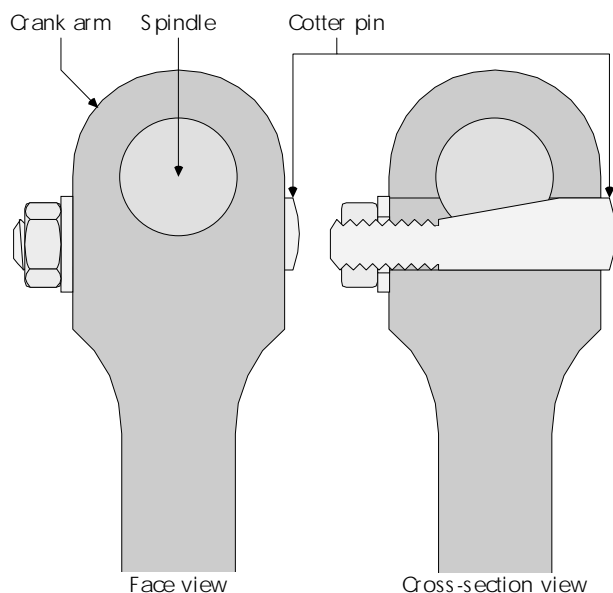

**21.1** Face view and cross-section view of the end of a cottered crank arm at the end joined to the bottom-bracket spindle.

**Cottered crank:** The term “cottered cranks” applies to a crank-arm type that once was seen on almost all European imports, but is now limited primarily to the sort of inexpensive Asian imports found in

department stores. The crank arms slip onto a round shaft and are retained by a pin (cotter pin) that goes through a hole in the arm and a slot in the shaft.

**Crank arm:** The lever arm that attaches to the bottom-bracket spindle at one end and the pedal at the other end. The right crank arm has chainrings (gears) attached to it, usually by means of chainring-mounting arms.

**Cotter pin:** A round shaft with a sloped and tapered flat along its length and a threaded stud at one end.

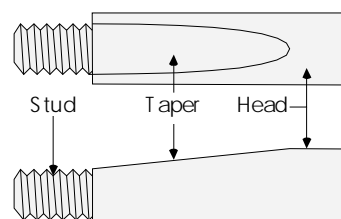

**21.2** A cotter pin.

**Cotter-pin taper (or “taper”):** The shaft of the cotter pin has a section cut off along the length of the pin that is cut at an angle to the axis of the shaft. This results in a flat surface that is sloped and tapers to a point at one end. This is the taper.

**Cotter-pin stud (or “stud”):** A threaded stud at one end of cotter pin onto which a retaining nut threads.

**Cotter-pin head (or “head”):** The end of the cotter-pin shaft without threads.

**Cotter-pin hole (or “pin hole”):** The cotter pin inserts in a small round hole in the crank arm into which the cotter pin is inserted. This hole is perpendicular to the hole in the crank arm for the bottom-bracket spindle.

**Cotter-pin stud (or “stud”):** The threaded stud at one end of the cotter pin onto which a retaining nut threads.

**Spindle hole:** The large round hole in the crank arm that the bottom-bracket spindle inserts in.

**Chainrings:** The gears attached to the right crank arm that drive the chain when pedaling.

**Chainring-mounting arms:** The arms (usually three, occasionally five) that go from one end of the crank arm out to the chainrings. The chainrings are attached to the end of the chainring-mounting arms. Chainring-mounting arms are also called *spider arms*.

## PREREQUISITES

See the **PREREQUISITES** section of the preceding chapter, **TAPER-FIT CRANK ARMS** (page 20-1). All prerequisites are the same for both types of crank designs.

## INDICATIONS

### *Maintenance cycles*

If properly installed, crank arms should not need any routine maintenance.

### *Bottom-bracket service*

Crank arms must be removed to adjust, overhaul, or replace the bottom bracket. There may be no apparent problems with the crank arms, but this is an excellent opportunity to check for potential problems.

### *Symptoms indicating loose crank arms*

One of the most persistent problems with crank arms is that they work loose. This can strand the rider — and it can easily destroy the arm that works loose, an expensive concern. Knocking or popping noises from the crank area are a warning sign that the arms may be loosening. But loose pedal parts and loose chainrings can cause similar noises, so check all these areas at the same time. When the arm makes a knocking sound or feels loose while pedaling, the situation is critical.

With proper installation, most riders do not need to periodically tighten the crank arms.

### *Symptoms indicating damaged crank arms*

When proper installation technique fails to keep the arm secure, it means the cotter-pin hole in the arm is deformed (enlarged or distorted). The crank arm should be replaced.

### *Symptoms indicating bent crank arms*

Crank arms bend sometimes when the bike is crashed, and they can bend from abusive jumping. The symptom of a bent crank arm is an oscillating sensation felt in the ankle while pedaling. This oscillation may feel like a twisting back and forth on the ball of the foot; it may feel like the outer edge of the foot is rocking up and down; or it may feel like both at once. The identical symptoms are caused by bent pedal shafts, which can easily be damaged by the same forces that damage crank arms. The first step is to remove the pedal and look at the end of the pedal shaft as it rotates. If the end does not oscillate, then it is the crank arm that is bent. If it does oscillate, new pedals are needed. If the symptom is still felt when riding with new pedals, then the arm is also bent.

### *Symptoms indicating damaged pedal-mounting threads*

Pedal-mounting threads can be damaged from improper pedal installation. The only symptom is difficulty threading in the pedal. Sometimes it is repairable, which is described in the chapter **PEDAL REMOVAL, REPLACEMENT, AND INSTALLATION** (page 24-6), but sometimes it is necessary to replace the crank arm.

## TOOL CHOICES

For many mechanics, the tool of choice to remove cotter pins is a hammer. This is a sure way to damage cotter pins, achieve inadequate security, and dramatically increase the time it takes to complete the job. Special cotter-pin presses are made by VAR and Park, but the Park CR-2 is clearly superior to use and less than one-third the price of the VAR. Some of this price savings is lost because it is a good idea to have two Park CR-2 tools.

One of the tools should be left in its original form and be used exclusively for pin installation. The second CR-2 should be permanently modified to make it more suitable for cotter-pin removal (and unsuitable for installation).

### *Modifying a Park CR-2 for pin removal*

The tip of the pressing shaft of the tool is a smooth shaft approximately 9mm long with an 11mm O.D. It needs to be modified on a grinder or with a file to be approximately 13–15mm long and less than 8.5mm O.D. This modification does not have to be very precise. It can be done on a grinding wheel in 1–2 minutes.

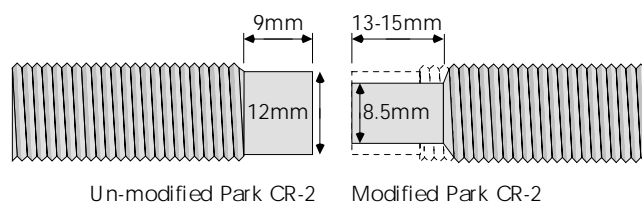

### *21.3 Modifying the end of a Park CR-2*

This modification allows the tip of the tool to go inside the pin hole in the arm, which is particularly useful when the pin jams or when the stud bends and must be broken off (common).

## TIME AND DIFFICULTY RATING

Crank-arm removal and re-installation is a 1–2 minute-per-arm job of little difficulty. Fitting a new replacement crank arm, which can include chainring and pedal removal and installation as well as front

derailleur adjustment, is a 10–45 minute job of little difficulty (unless derailleur adjustment is included, in which case difficulty may be high).

## COMPLICATIONS

### *Exact replacement cotter pins not available*

It is very unusual to be able to find exact replacement cotter pins. Included in this chapter are guidelines for determining suitability of a nonidentical replacement and how to accommodate for a pin that is not suitable (page 21-5).

### *Replacement arm does not fit spindle*

Depending on the country of origin, there is some variation in spindle and spindle-hole diameters. English and Japanese are interchangeable. French and Italian are interchangeable.

### *Replacement arm changes chainring clearance*

There is usually a 1–2mm range of position of the arm on the spindle. First, try sliding the arm in or out to improve the situation.

A nonidentical right-side replacement arm may be suitable fit to a spindle, but not necessarily put the chainrings in the same position relative to the frame. This could be a problem if the chainrings end up closer to the frame. The following procedures have steps for checking the original clearance and the clearance after installing a new right arm.

### *Replacement arm changes chainline*

There is usually a 1–2mm range of position of the arm on the spindle. First, try sliding the arm in or out to improve the situation.

Because a replacement right-side arm can change the chainring positions, it can change the alignment of the chainrings to the rear cogs (chainline). The following procedures have steps for checking chainline before and after, but the separate **CHAINLINE** chapter should be referred to for help in how to measure chainline (page 27-5) and how to identify whether an error is significant (page 27-3).

### *New chainring-size/position changes front-derailleur adjustment*

There is usually a 1–2mm range of position of the arm on the spindle. First, try sliding the arm in or out to improve the situation.

If installing a replacement right-side crank arm, the chainrings may move in or out. This would necessitate changing both limit screws and the cable setting on the front derailleur. If the replacement crank arm has a large chainring of a different size, then derailleur height and rotation would need to be reset (which leads to limit screw and cable adjustment, as well).

## ABOUT THE REST OF THIS CHAPTER

The rest of this chapter is the procedure for crank-arm removal and installation. There are double check-boxes next to all the steps that would be done twice, once for each crank arm. It includes all the necessary steps for crank-arm replacement except that it refers to other chapters for pedal and chainring removal and installation.

## CRANK-ARM REMOVAL AND INSTALLATION

### IF REPLACING ARM(S) OR TO FACILITATE CLEANING

1. [ ] [ ] Remove pedal(s) (optional). See *PEDAL REMOVAL, REPLACEMENT, AND INSTALLATION* procedure (page 24-3).

### PREPARATION AND PRE-REMOVAL INSPECTIONS

In the next step, measure the clearance between the right-crank assembly and the chain stay. The chain stay is the frame tube that runs from the bottom bracket to the rear dropout. If the bike has raised chain stays (they connect to the seat tube above the front derailleur), measure to the side of the seat tube instead. The measurement is useful even if just re-installing the same crank arm, for two reasons.

Due to frame flex and chainring flex, there must be at least 2mm clearance between any part of the right-crank assembly and the chain stay. Otherwise, rubbing that can damage the frame may occur while the bike is being ridden. Measuring before removal can reveal a problem, or borderline problem, before going to the trouble of re-installation the arm. If clearance is poor before removal, it will be necessary to

## 21 – COTTERED CRANK ARMS

check and replace the arm if it is found to be worn out, or put in a longer bottom-bracket spindle if the arm is fine. If the clearance is marginal before removal, measuring it is a warning to check carefully when the arm is re-installed.

After re-installing the original arm or installing a replacement arm, measuring the change in the clearance reveals whether it will be necessary to readjust the front derailleur.

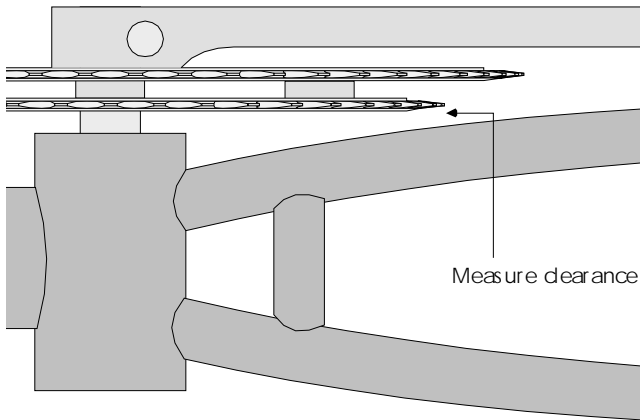

**21.4** Use a stack of feeler gauges to measure the clearance between the chain stay and the part of the crank assembly that comes closest to rubbing the chain stay.

**2. [ ] Measure clearance between chain stay and part of right crank that comes closest to chain stay (usually inner chainring or bolt heads holding on inner chainring, but occasionally another chainring). Record measurement here: \_\_\_\_\_ mm. If bike has raised chain stays, measure to side of seat tube.**

In the next step, measure the chainline error (detailed procedure on page 27-5). Chainline is covered in its own chapter. Chainline is the alignment of the front gears to the rear gears. It affects drive-train noise and shift performance. Measure chainline now and then again after re-installing the original right arm or a new right arm. This measurement allows you to know whether chainline has improved, stayed the same, or gotten worse, in which case it would be necessary to check for symptoms in order to determine whether the error was significant. (See page 27-3.)

**3. [ ] Measure chainline error: Chainrings out (+) or in (-) (circle one)? Amount: \_\_\_\_\_**

In the next step, the position of the right crank-arm face relative to the right end of the spindle is measured, using the depth gauge of a caliper. There is usually a range of position in which the arm can be installed. Taking this measurement and reestablishing it during re-installation avoids messing up the front-derailleur adjustment.

**4. [ ] Measure position of face of right crank arm relative to right end of spindle.**

**Spindle protrusion/recess: \_\_\_\_\_ mm.**

## CRANK-ARM REMOVAL

From this point on, steps that need to be repeated for both arms (if servicing both arms) have two check-boxes. One is to use for the first arm, and one for the second arm. If only servicing one arm, use one check-box only and do not repeat the step for the second arm.

**5. [ ] [ ] Remove nut and washer from cotter pin.**

Cotter pins can be difficult to remove; when they are, the stud will almost always bend. Prevent this as much as possible by using penetrating oil, as indicated in the next step.

**6. [ ] [ ] Flood both ends of pin with penetrating oil.**

In the next step, cotter-pin removal is attempted. It is not unusual for the stud to bend before removal is accomplished. If this occurs, don't waste time straightening the stud and trying removal again. Bend the stud back and forth until it snaps off and continue the removal process without the stud. The modified CR-2 is required for this purpose.

If you have only the non-modified Park CR-2, the best approach is to break off the stud (bend it back and forth), then insert a 8–10mm length piece cut from the head-end of a used cotter pin between the CR-2 shaft and the remainder of the stud. This insert needs to be smaller or equal to the diameter of the cotter pin being removed. The insert will have a tendency to cock to the side and jam. The modified CR-2 is a much better solution to this common problem.

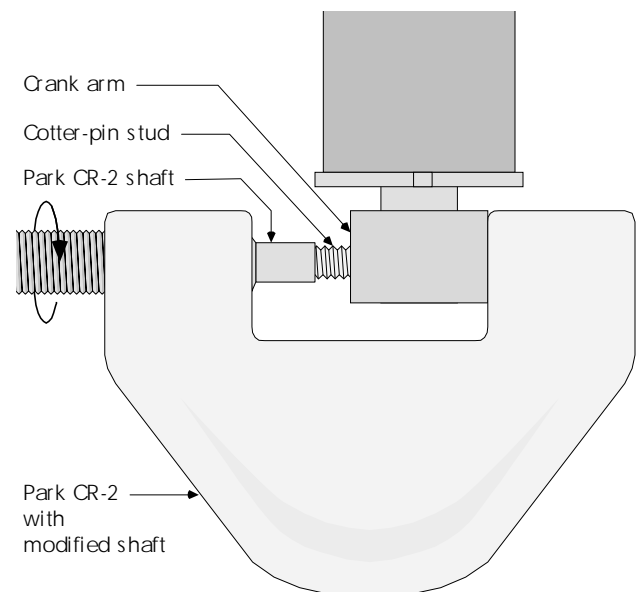

**21.5** Correct set up of Park CR-2 for cotter-pin removal.

- 7. [ ] [ ] Install modified CR-2 so end of shaft is against stud and turn handle clockwise to drive cotter pin fully out.
- 8. [ ] [ ] Pull arm off end of spindle.

**INSPECTION**

- 9. Inspect pin holes in arms for enlargement and for being ovalized:
  - [ ] Right arm OK? not OK? (circle one). *If not OK, arm should be replaced.*
  - [ ] Left arm OK? not OK? (circle one). *If not OK, arm should be replaced.*

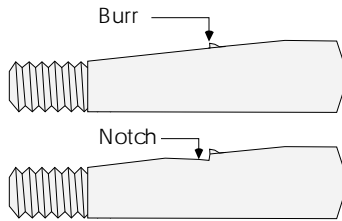

21.6 Top cotter pin has burr, but can be reused. Bottom one is notched and must be replaced.

- 10. Inspect pin tapers on pins for notches or deformation (burrs may be filed off):
  - [ ] Right pin OK? not OK? (circle one). *If not OK, pin should be replaced.*
  - [ ] Left pin OK? not OK? (circle one). *If not OK, pin should be replaced.*
- 11. Thread nuts back onto studs to check for damaged studs:
  - [ ] Right pin OK? not OK? (circle one). *If not OK, pin should be repaired or replaced.*
  - [ ] Left pin OK? not OK? (circle one). *If not OK, pin should be repaired or replaced.*

**IF REPLACING RIGHT ARM, OR TO FACILITATE CLEANING**

- 12. [ ] Remove chainrings (optional). See *CHAINRING REMOVAL, REPLACEMENT, AND INSTALLATION* procedure (page 23-9) if removing or replacing chainrings.

**CRANK-ARM CLEANING**

- 13. [ ] Clean crank arms and chainrings (if any).

**DETERMINE REPLACEMENT-COTTER-PIN SUITABILITY**

Exact replacement cotter pins are almost impossible to find. Use the following guidelines to determine suitability of a replacement cotter pin.

1. Pin diameter must match. (Common sizes are 9.0mm and 9.5mm, but 8.0mm and 8.5mm sizes also exist.)
2. Pressed-in pin must have head protruding from arm. If not, different pin must be used. See example 1 (figure 27.7).
3. Pressed-in pin must have enough stud protruding to engage washer and nut. Pin can be filed to improve this condition. See example 2 (figure 27.8).
4. Pressed-in pin should not have full stud exposed. Washers with I.D. larger than pin can be used over pin shaft to improve this condition. See example 3 (figure 27.9, page 21-6).
5. Pin-taper angles must match or arms will not be 180° apart. Both pins should be replaced to avoid this problem. See example 4 (figure 27.10, page 21-6).

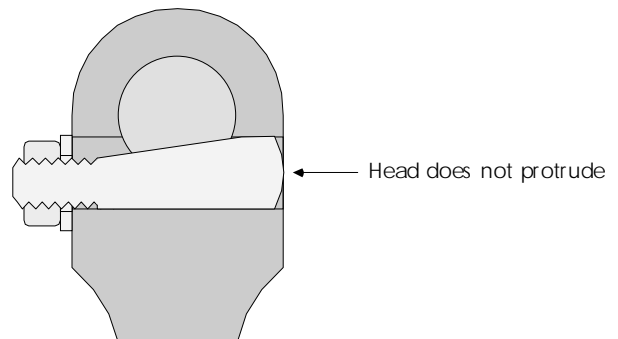

21.7 Example 1: The cotter pin in this picture does not have enough head protruding to allow further pressing after break-in.

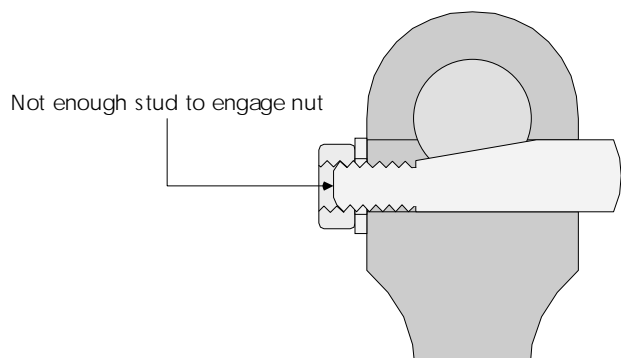

21.8 Example 2: The cotter pin in this picture does not have enough stud protruding. The taper can be filed deeper to improve this condition.

## 21 - COTTERED CRANK ARMS

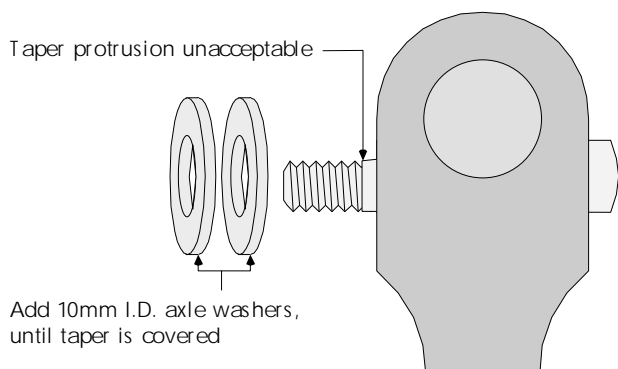

**21.9** Example 3: The cotter pin in this picture has too much of the stud end protruding. Add washers to improve this condition.

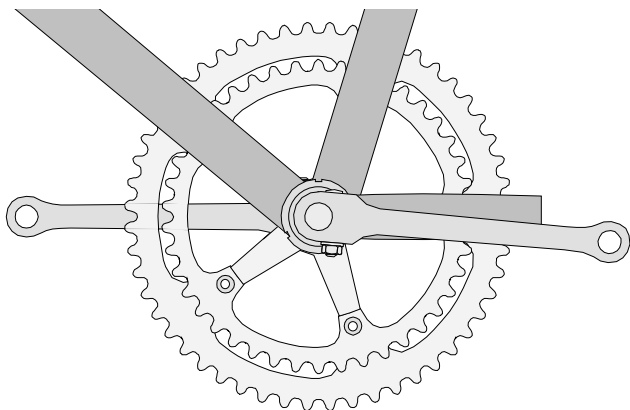

**21.10** Example 4: The arms are not 180° apart because the cotter pins do not have the same taper angle. Both pins should be replaced with identical replacements to solve this problem.

### Filing cotter pins to improve fit

A flat file can be used to file the taper deeper so that a pin will insert further. Do not try to change the angle of the taper, just its depth. A VAR 371 is a tool designed to hold the cotter pin for filing. Although not required, it makes an awkward job effortless.

## CRANK-ARM INSTALLATION

14. [ ] [ ] Install chainrings if removed. See **CHAINRING REMOVAL, REPLACEMENT, AND INSTALLATION procedure** (page 23-10).
15. [ ] [ ] Clean cotter pin, pin hole, and spindle flat with acetone or alcohol.
16. [ ] [ ] Slide crank arm onto spindle.

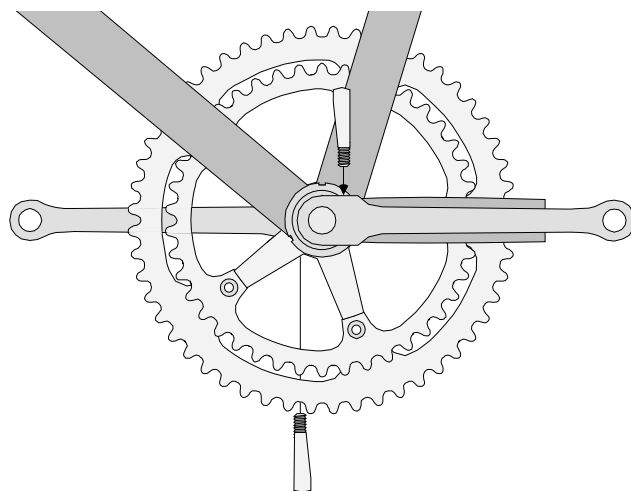

**21.11** When the cotter pin in the left arm is "head-up," the pin in the right arm should be "head-down."

17. [ ] [ ] Slide cotter pin into pin hole. (When installing second arm, be sure pin heads point opposite directions when viewed simultaneously.)
18. [ ] [ ] Position right arm (if re-installing original) to restore measurement from step 4.

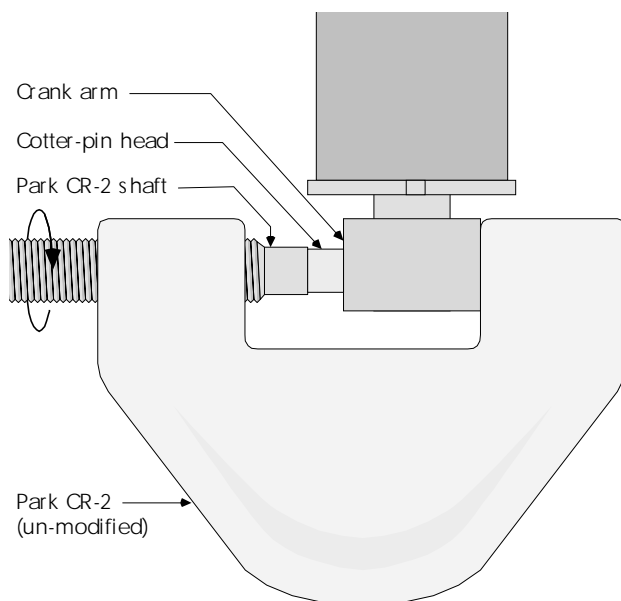

**21.12** Setup for using the CR-2 to press in the cotter pin.

19. [ ] [ ] Use CR-2 to press in pin fully. With handle extended fully to one end, minimum of 55 pounds of force is required at 4".
20. [ ] [ ] Grease stud threads.
21. [ ] [ ] Thread on retention nut and secure to 60in-lbs (20lbs@3").

## CHECKING FIT OF REPLACEMENT CRANK ARM

**NOTE:** Skip to step 25 if arms installed are same ones removed, not replacements.

### *Checking chainring fit if replacement arm is a right arm*

If using old chainrings with a new crank arm, check the **CHAINRINGS** chapter (page 23-5) to determine whether the new arm is compatible with the chainrings before installing the chainrings. Chainring compatibility is not just a matter of whether the mounting holes in the chainrings and the crank arm match up. With some chainrings, spacing between them is critical and not universal.

In the next step, measure the right chainring clearance with the new arm installed to check if the chainring position has changed. Be concerned with discovering whether a clearance problem to the chain stays has been created or solved, and whether the chainrings have moved enough to require readjusting the front derailleur.

#### 22. Measure chainring-to-chainstay clearance and check one of following choices:

- Clearance is  $\pm 2$ mm, but is more than .2mm different than number in step 2. *Front-derailleur limit screws and cable will need adjustment.* (Measure to seat tube if raised-chain-stay bike, ignore minimum clearance.)
- Clearance is  $< 2$ mm, *replacement arm is unacceptable to use with existing spindle.* (Skip this step for raised-chain-stay bikes.)
- Clearance is different by  $\pm .2$ mm from number in step 2, *front-derailleur adjustment is not needed.* Arm is a good fit.

In the next two steps, measure the chainline after installing a new right crank arm to determine whether it has been changed enough to create or solve a problem. Consider not only whether there is a measurable error, but whether the error has changed enough *to introduce or eliminate chainline-error symptoms.* See the **CHAINLINE** chapter for information about how to measure chainline error (page 27-5) and symptoms of chainline error (page 27-3).

#### 23. Measure chainline error, record here: Chainrings *out (+)* or *in (-)* (circle one)? Amount: \_\_\_\_\_

#### 24. Compare step 23 to number and direction in step 3, and choose one of following choices:

- Error is equal to step 3, arm is acceptable if no chainline-error symptoms were experienced with original arm.

- Error is in same direction but less than step 3, arm is acceptable unless previous chainline error was unacceptable and change is not enough to eliminate symptoms. Bike should be evaluated for chainline-error symptoms.
- Error is in new direction. Bike should be evaluated for chainline-error symptoms.
- Error is in same direction but greater. Inspect bike for chainline-error symptoms.

## INSTALL PEDALS

25.  Install pedal(s) if removed. See *PEDAL REMOVAL, REPLACEMENT, AND INSTALLATION* procedure (page 24-4).

***COTTERED-CRANK-ARM TROUBLESHOOTING***

<i>Cause</i>	<i>Solution</i>
<b>NOTE:</b> Symptoms not unique to cotter-pin crank arms are found in the troubleshooting chart in the previous chapter <b>TAPER-FIT CRANK ARMS</b> (page 20-14).	
<b>SYMPTOM:</b> <i>Cotter pin becomes loose quickly after installation.</i>	
Was not installed with enough force.	Use minimum of 55 lbs. force at 4" on Park CR-2.
Lubrication present on pin, pin hole, or spindle flat.	Clean all mating surfaces with acetone or alcohol.
Under-sized pin has been used.	Cotter-pin diameter must match pin-hole diameter closely.
Pin hole in arm was enlarged by being ridden with loose pin too long.	Replace arm.
Pin is poor fit (too much stud protruding), and retaining-nut washer stopped against shaft of pin instead of arm surface.	Replace pin, or use washers with an I.D. larger than pin shaft between arm and retaining-nut washer.
Head swells when hammer is used for installation.	Replace pin and use press tool for installation.
<b>SYMPTOM:</b> <i>Stud folds over during pin-removal attempt.</i>	
Failure to use penetrating oil before removal.	Break stud off and perform removal without stud.
Use of hammer for pin removal.	Break stud off and perform removal without stud, using modified Park CR-2.
<b>SYMPTOM:</b> <i>Cotter pin is extremely difficult to remove, in some cases even though arm is loose on spindle.</i>	
Bike has been ridden while pin was loose, bending pin in arc around spindle.	No tricks available. Use modified Park CR-2, penetrating oil, and cheater bar on tool handle.
<b>SYMPTOM:</b> <i>Taper has deep notch in its surface.</i>	
Bike has been ridden while pin was loose, pin has been bearing against edge of spindle flat.	Replace pin and tighten adequately.
<b>SYMPTOM:</b> <i>Arms are not 180° apart.</i>	
Matching pins are not installed with heads facing opposite directions, when viewed simultaneously.	Reverse direction of one pin.
Non-matching pin has been installed.	Remaining original pin should be replaced with replacement pin that matches other side.
<b>SYMPTOM:</b> <i>Retaining-nut threads or stud threads stripped out.</i>	
Retaining nut over-tightened.	Replace nut, tighten nut to 60in-lbs (20lbs@3").
Retaining nut was used to install cotter pin.	Replace nut. Retaining nut cannot be used for installing pin.
<b>SYMPTOM:</b> <i>Cotter-pin head is flush with arm surface and cannot be pressed in further to secure arm.</i>	
Pin worn out or wrong-size pin.	Install better-fitting cotter pin.
<b>SYMPTOM:</b> <i>Washer and retaining nut do not bear against crank arm when tightened fully.</i>	
Poor fitting pin has been used.	Replace pin, or use washers with I.D. larger than pin shaft between arm and retaining-nut washer.
<b>SYMPTOM:</b> <i>Not enough stud protrudes to engage washer and retaining nut.</i>	
Poor-fitting cotter pin.	Remove pin and file taper deeper, or use different pin.