

# 20 – TAPER-FIT CRANK ARMS

## ABOUT THIS CHAPTER

This chapter is about removing and installing taper-fit crank arms (commonly called cotterless crank arms), as well as installing replacement crank arms. The **COTTERED CRANK ARMS** chapter covers cottered crank arms (page 21-1). The **ONE-PIECE CRANK ARMS** chapter covers one-piece crank arms (page 22-1). There is also a **CHAINRINGS** chapter (page 23-1), which should be referred to if the chainrings will be removed, replaced, or secured. The chapter **PEDAL REMOVAL, REPLACEMENT, AND INSTALLATION** (page 24-1) includes information about pedal removal and installation — a job that is often done as part of crank-arm removal and installation.

A variation of this design is the splined-fit crank arm types being made by Shimano. These are discussed in the final section of this chapter **SHIMANO SPLINE-FIT CRANK ARMS** (page 20-16).

## GENERAL INFORMATION

### TERMINOLOGY

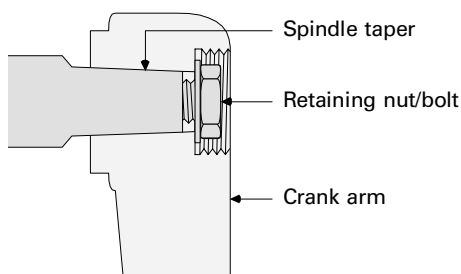

20.1 Cross-section of a taper-fit crank arm attached to a spindle.

**Taper-fit crank:** A crank design that has a tapered square hole in the crank arm that is pressed onto a tapered, square bottom-bracket spindle.

**Cotterless crank:** The term “cotterless cranks” is becoming obsolete and probably ought to be replaced. Decades ago, almost all quality bicycles had crank arms that slipped onto a round shaft and were retained by a pin (cotter pin) which went through a hole in the crank arm and a slot in the shaft. When a new style of crank (with no cotter pins) was invented, it was named by how it was different from the existing design, hence

the name “cotterless crank.” This design uses a square, tapered shaft with four flats. The crank arm has a similar tapered hole. A bolt or nut presses the arm onto the tapered shaft and the friction of the tapered shaft jamming into the tapered hole holds it all together. This taper-fit design is predominant now, and is the design that this chapter focuses on. From here on, the word “cotterless” is dispensed with, and the dominant design of today will be called a “crank arm” without repeatedly modifying it with any adjective.

**Crank arm:** The lever arm that attaches to the bottom-bracket spindle at one end and the pedal at the other end. The right crank arm has chainring(s) (gears) attached to it, usually by means of chainring-mounting arms.

**Chainrings:** The gears attached to the right crank arm that drive the chain when pedaling.

**Chainring-mounting arms:** The arms (usually five) that go from the end of the crank arm out to the chainrings. The chainrings are attached to the end of the chainring-mounting arms, which are also called *spider arms*.

**Crank-arm extractor:** The tool used for removal of the crank arm from the bottom-bracket spindle.

**Extractor body:** The portion of the crank-arm extractor that threads directly into the crank arm.

**Extractor shaft:** The portion of the crank-arm extractor that threads into the extractor body and pushes against the end of the bottom-bracket spindle.

**Extractor threads:** These are the threads in the crank arm that the crank-arm extractor threads into.

## PREREQUISITES

### ***Pedal removal and installation***

Before removing a crank arm, the pedal should be removed. Pedals are much easier to remove with the crank arm still attached to the bike. If removing the crank arm(s) for simple maintenance (cleaning) or bottom-bracket service, pedal removal is optional. Although it may not appear so, pedal removal is generally not required for chainring removal; although, this is something that may be done to the crank arm once it is off. See the **PEDAL REMOVAL, REPLACEMENT, AND INSTALLATION** chapter for pedal removal (page 24-3) and installation (page 24-4).

### ***Chainring removal and installation***

If replacing a right crank arm, chainring removal will be required. For anything else, chainring removal is strictly optional. It is easier to do a thorough job of cleaning the cranks arms and chainrings with the chainrings removed. See the **CHAINRINGS** chapter for chainring removal (page 23-8) and installation (page 23-10).

### ***Front-derailleur adjustment and replacement***

If replacing a right crank arm with a non-identical one, the new one may position the chainrings slightly further in or out, requiring additional adjustment of the derailleurs limit screws and cable tension. If replacing the right crank-arm/chainring assembly with an identical arm, but a larger or smaller chainring, then the front-derailleur height must be changed. When changing the height of the front derailleur, the derailleur's rotational adjustment may also change, which in turn may affect limit screws and cable tension. See the **FRONT DERAILLEURS** chapter for front-derailleur adjustment (page 33-10).

Front-derailleur replacement is only required in two cases: if installing a new crankset or right crank arm with chainrings that have less than an 8-tooth difference between the largest ring and the next smaller one; or when the front derailleur was designed for a triple chainring with a 10-tooth or more difference. See the **FRONT DERAILLEURS** chapter to tell how front-derailleur capacity has been exceeded (page 33-4). If installing a "micro-drive," Shimano "compact drive," or other crankset with reduced-size chainrings, there could be other problems with front-derailleur capacity.

### ***Chainline error***

If replacing a right crank arm with one that is *not* identical, the chainrings may end up further in or out. While this might be acceptable in terms of chainring-to-frame clearance and/or front-derailleur range of motion, it might change the chainline alignment. This alignment affects front-derailleur performance, drive-train noise, and drive-train wear. Only by knowing how well the chainrings aligned originally, and combining that information with how much further in or out the chainrings will end up relative to the frame, can you determine whether the new crank arm is acceptable for use with the existing bottom-bracket spindle.

### ***Rear-derailleur replacement***

In the case of installing a new crankset or a new right arm with different-size chainrings than the original ones, it is possible to exceed the capacity of the rear derailleur to eliminate the chain slack when the chain is in the smallest chainring and smallest rear cog. It is the difference in number of teeth between the smallest and largest chainring that is important, not the absolute size of either chainring. See the **REAR DERAILLEURS** chapter (page 32-6) to determine if the capacity matches the new chainring set.

## **INDICATIONS**

### ***Maintenance cycles***

If properly installed, crank arms should not need any routine maintenance. Other books and periodicals recommend routine tightening of crank-arm mounting nuts/bolts. This would only be necessary if they were under-tightened initially. Routine tightening of the nuts/bolts without using a torque wrench to make sure that they are not being over-tightened invites damage to the arm from over-tightening.

### ***New bikes***

If assembling a new bike, removing and re-installing the crank arms is recommended. This is the only way to know that the mounting surfaces are properly prepared and the torque is correct. It is an unfortunately common problem with new bikes that the crank arms work loose and are destroyed. Although this would be covered by warranty, it would be nicer to avoid it altogether.

### ***Bottom-bracket service***

To adjust, overhaul, or replace the bottom bracket, crank-arm removal is required. There may be no apparent problems with the crank arms, but this is an excellent opportunity to check for potential problems.

### ***Symptoms indicating loose crank arms***

One of the most persistent problems with crank arms is that they work loose. This can strand the rider, and it can easily destroy the arm that works loose — an expensive concern. Creaking noises from the crank area are a warning sign that the arms may be loosening, but loose pedal parts and loose chainring bolts can cause similar noises, so check all these areas at the

same time. When the arm makes a knocking sound or feels loose while pedaling, the situation is critical. If it is not too late, it may be possible to save the arm by not pedaling on it until it can be secured. Pedaling lightly, for even one block, may destroy the arm.

With proper installation, most riders do not need to periodically tighten the crank arms. Other books and magazine articles often state “re-tighten crank arms every 100 miles,” or something similar. The crank arm would be the most under-designed part on the bicycle if this was the case, and bike shops would be selling as many replacement crank arms as they do inner tubes. In fact, it is possible to damage crank arms from routine tightening without a torque wrench, which is why it is not recommended. With a torque wrench, crank arms can be regularly checked without risk. If they are remaining tight (as they should), then the torque wrench will show this without adding any tightness. If they have worked loose, the torque wrench will tighten them back to the original torque. If they work loose more than once, consider a higher torque. This “torque checking” (as opposed to periodic re-tightening) is an excellent form of preventive maintenance.

### ***Symptoms indicating damaged crank arms***

When the normal installation techniques (plus using the *maximum* recommended torque) fail to keep the arm secure, it means the tapered square hole in the arm is deformed (enlarged or distorted). The crank arm should be replaced.

### ***Symptoms indicating bent crank arms***

Crank arms bend sometimes when the bike is crashed, and they can bend from abusive jumping. The symptom of a bent crank arm is an oscillating sensation felt in the ankle while pedaling. This oscillation may feel like a twisting back and forth on the ball of the foot, or like the outer edge of the foot is rocking up and down, or it may feel like both at once. The identical symptoms are caused by bent pedal shafts, which can easily be damaged by the same forces that damage crank arms. Depending on the relative strength of the crank arm or pedal shaft, either may be more likely to bend. The first step is to remove the pedal and look at the end of the shaft as it rotates. If the end does not oscillate, then it is the

crank arm that is bent. If it does oscillate, new pedals are needed. If the symptom is still felt when riding with new pedals then, the arm is also bent.

### ***Symptoms indicating damaged pedal-mounting threads***

Pedal-mounting threads can be damaged from improper pedal installation. The only symptom is difficulty threading in the pedal. Sometimes it is repairable, which is described in the chapter **PEDAL REMOVAL, REPLACEMENT AND INSTALLATION** (page 24-6), but sometimes it is necessary to replace the crank arm.

### ***Symptoms indicating damaged crank-arm-removal threads***

The crank-arm-removal tool threads into the crank arm where the bolt/nut dustcap comes out. Damage to these threads will be indicated by difficulty threading in the crank extractor, or by the extractor pulling out of the crank-arm threads when attempting a crank-arm removal. These threads can be damaged from failure to protect them with the bolt/nut dustcap, improper removal tool use, or failure during removal due to over-tight arm installation. In some cases, this thread damage may be repairable, but in most cases it is not. When the threads are damaged beyond repair, the arm should be replaced. There is a section at the end of this chapter on repair of these threads, and how to remove the arm when the threads are unrepairable.

### ***Symptoms indicating cracked crank arms***

Crank arms can crack in a number of places. Sometimes a crack will develop between the pedal mounting hole and the end of the arm. Sometimes a crack will develop at the crotch of the chainring-mounting arms (spider arms) and the crank arm. Sometimes a crack will develop between a corner of the tapered square hole and the mounting end of the arm. These cracks may make themselves known through creaking noises, but that is not likely. Most likely, the cracks will be discovered through inspection. Whenever servicing the crank arms (especially when cleaning), inspect in all these areas for cracks. If the arm cracks and is not replaced, it can result in a catastrophic failure, which can lead to serious injury.

## 20 – TAPER-FIT CRANK ARMS

### TOOL CHOICES

The design or brand of crank arm and spindle will determine the tools needed.

Table 20-1 (below) covers all tools for the job. The preferred choices are in **bold**. A tool is preferred because of a balance among: ease of use, quality, versatility, and economy. When more than one tool for one function is in **bold**, it means that several tools are required for different configurations of parts.

Although some distributors sell special pullers for removing crank arms with stripped threads, none of these tools are listed here because the best techniques for doing the job do not require any special tools.

### TIME AND DIFFICULTY RATING

Crank-arm removal and re-installation is a 1–2 minute-per-arm job of little difficulty. Fitting a new replacement crank arm, which can include chainring and pedal removal and installation, as well as front-derailleur adjustment, is a 10–45 minute job of little difficulty (unless derailleur adjustment is included, in which case difficulty may be high).

**TAPER-FIT CRANK-ARM REMOVAL TOOLS** (table 20-1)

Tool	Fits and considerations
<b>EXTRACTORS</b>	
Campagnolo 770	22 × 1mm RH-thread extractor, works with bolt-type spindles only
Campagnolo 1170005	22 × 1mm LH-thread extractor for C-Record track cranks and Campagnolo road cranks that have an Allen-wrench removal system that is absent
<b>Park CCP-2</b> (replaces CCP1 that had poor tip design)	22 × 1mm & 23 × 1mm extractor with built in handle for removing common crank arms and T.A. brand crank arms from <i>both</i> nut-type or bolt-type spindles (poor leverage due to handle length and thinness)
<b>Park CWP-5</b>	22 × 1mm RH-thread extractor, works with nut-type and bolt-type spindles
Shimano TL-FC10	22 × 1mm RH-thread extractor, works with bolt-type spindles only
Sugino Mighty 202	22 × 1mm RH-thread extractor, works with bolt-type spindles only
Sugino Maxi 203	22 × 1mm RH-thread extractor, works with nut-type spindles only
VAR 11	22 × 1mm RH-thread extractor, works with bolt-type spindles only
VAR 12	23 × 1mm (fits T.A.), removes from bolt-type spindles only
<b>VAR 22/2</b>	Fits older Stronglight cranks with 16mm bolt and unique 23.35 × 1mm thread
VAR 392/2	22 × 1mm RH-thread extractor, works with bolt-type spindles only
VAR 393	22 × 1mm & 23 × 1mm extractor for removing common crank arms and T.A. brand crank arms from <i>only</i> bolt-type spindles (poor mechanical advantage)
VAR 932	Use on crank arms with stripped threads, expensive, very limited effectiveness
<b>OTHER CRANK-ARM TOOLS</b>	
<b>Bicycle Research TC-8</b>	Thread chaser, repairs mangled 22 × 1mm crank-arm threads
<b>Shimano TL-FC20</b>	Fits 2 pin-hole dust cap on older Shimano crank arms
<b>VAR 22/3</b>	23 × 1mm tap for repairing stripped 22 × 1mm arms
Stein CES	Converts stripped 22 × 1mm threads to 24 × 1.5mm. Comes with shop extractor (24 × 1.5mm) and one-key-release system to be left installed in crank. Expensive.

## COMPLICATIONS

### ***Dustcap will not unthread***

Cross-threading or corrosion can turn the relatively simple task of removing a crank-arm dustcap into an ordeal. The tool-fitting in the dustcap usually strips out. The best solution is to drill two holes in the face of the dustcap and use an adjustable pin spanner to get it out. Some plastic threaded dustcaps with this problem will just rip apart instead of unthreading. In this case, there is no choice except to use some sort of pick or pry tool to dig out the remaining pieces bit-by-bit.

### ***Extractor will not thread into arm***

*Never force the extractor in!* The first thing to check when the extractor will not thread in is whether the bolt/nut has actually been removed. Next, try more carefully to keep the axis of the extractor aligned with the axis of the spindle rather than perpendicular to the face of the crank arm. If this does not solve the problem, then the threads are probably mangled. There is a section at the end of the chapter about repairing mangled threads.

### ***Threads are stripped out in arm***

If the threads are stripped out before crank-arm removal is attempted, then it is simply a matter of removing and replacing the arm (procedure at end of this chapter). If they strip while attempting removal, it is important to determine why. If correct removal technique has been used, then the failure has occurred because the arm was too tight. This is not unusual. The responsibility lies with the last person to install the arm. If there is not 100% certainty that the removal technique was correct, then the shop owes the customer a replacement arm.

### ***Chainrings wobble excessively with crank in all four mounting positions***

Lack of precision with the spindle flats and with the square hole in the arm can effect the amount of chainring wobble that occurs in each of the four possible positions that the arm can be mounted on a spindle. If the wobble is unacceptable in the best of these four positions, then the problem is with the chainring-mounting arms or the chainrings themselves, and not with the crank-arm/spindle fit. Both of these problems are addressed in the **CHAINRINGS** chapter (page 23-3 and 23-12).

### ***Replacement arm does not fit spindle***

It is not unusual for one brand of crank arm to not fit another brand's spindle. Sometimes there are even compatibility problems between different models or

years of the same brand. Many older European brand crank arms cannot be used with most spindles manufactured in Asia. New Shimano crank arms cannot be used with anything but new Shimano spindles. The removal and installation procedures in this chapter include inspections to determine whether an arm and spindle are compatible. Unfortunately, it is not practical to create a table of compatibility for the huge and ever-changing selections of spindles and crank arms.

### ***Replacement arm changes chainring clearance***

A non-identical replacement of the right-side crank arm may fit the spindle, but not necessarily put the chainrings in the same position relative to the frame. If the chainrings end up closer to the frame, it could be a problem. The following procedures have steps for checking the original clearance and the clearance after installing a new right arm.

### ***Replacement arm changes chainline***

Because a replacement right-side arm can change the chainring positions, it can change the alignment of the chainrings to the rear cogs (chainline). The following procedures have steps for checking chainline before and after, but the separate **CHAINLINE** chapter should be referred to for help in how to measure chainline (page 27-5) and how to identify whether an error is significant (page 27-3).

### ***New chainring size/position changes front-derailleur adjustment***

If installing a replacement right-side crank arm, the chainrings may move in or out. This would necessitate changing both limit screws and the cable setting on the front derailleur. If the replacement crank arm has a large chainring of a different size, then derailleur height and rotation would need to be reset (which leads to limit screw and cable adjustment as well).

## ABOUT THE REST OF THIS CHAPTER

The rest of this chapter is divided into two parts. The first part is the procedure for crank-arm removal and installation. There are double check-boxes next to all the steps that would be done twice, once for each crank arm. It includes all the necessary steps for crank-arm replacement; however, it refers to other chapters for pedal and chainring removal and installation. The second part is about how to remove a crank arm with damaged extractor threads.

# NORMAL CRANK-ARM REMOVAL AND INSTALLATION

## IF REPLACING ARM(S) OR TO FACILITATE CLEANING

1. [ ] [ ] [ ] **Optionally, remove pedal(s). See PEDAL REMOVAL, REPLACEMENT, AND INSTALLATION worksheet.**

## PREPARATION AND PRE-REMOVAL INSPECTIONS

In the next step, measure the clearance between the right-crank assembly and the chain stay. The chain stay is the frame tube that runs from the bottom bracket to the rear dropout. If the bike has raised chain stays (they connect to the seat tube above the front derailleur), measure to the side of the seat tube instead. The measurement is useful, even if just reinstalling the same crank arm, for two reasons.

First, due to frame flex and chainring flex, there must be at least 2mm clearance between any part of the right-crank assembly and the chain stay. Otherwise, frame damage may occur while the bike is being ridden. Measuring before removal reveals a problem, or borderline problem, before going to the trouble of re-installing the arm. If clearance is poor before removal, it will be necessary to check and replace a worn-out arm, or put in a longer bottom-bracket spindle if the arm is fine. If the clearance is marginal before removal, measuring will alert you to a potential problem when the arm is re-installed.

Second, after re-installing the original arm or installing a replacement arm, measuring the change in the clearance reveals whether it will be necessary to re-adjust the front derailleur.

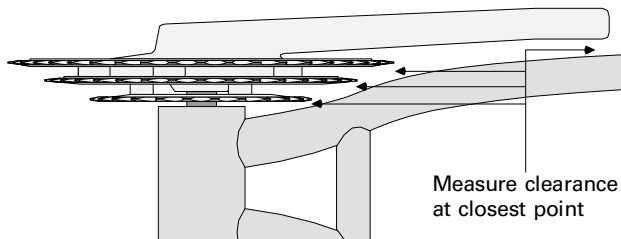

20.2 Use a stack of feeler gauges to measure the clearance between the chain stay and the part of the crank assembly that comes closest to rubbing the chain stay.

2. [ ] Measure clearance between chain stay and part of right crank that comes closest to chain stay (usually inner chainring or bolt heads holding on inner chainring, but occasionally another chainring). Record measurement here: \_\_\_\_\_. If bike has raised chain stays, measure to side of seat tube.

In the next step, measure the chainline error. Chainline is the alignment of the front gears to the rear gears, and is covered extensively in the **CHAINLINE** chapter (page 27-6). It affects drive-train noise and shift performance. Measure it before making any changes, and then again after re-installing the original right arm or a new right arm so it will be known whether chainline ended up worse, in which case it would be necessary to check for symptoms in order to determine whether the error was significant.

3. [ ] **Measure chainline error:**  
Chainrings **out (+)** or **in (-)** (circle one)?  
Amount: \_\_\_\_\_ mm
4. [ ] [ ] **Remove dust cap(s) (if any). (Except crank arms with built-in removers. Evidence will be an Allen bolt visible through a hole in a heavy duty steel dust cap.)**

If the bolt being removed in step #5 is an Allen bolt, then there is a possibility that the crank arm has a built-in removal system. In this case, the arm will come off as the bolt is loosened, and the arm and bolt will stay together as a unit. There are not special concerns or precautions necessary.

**NOTE: Skip ahead to step 11 if the arm and bolt come off as a unit.**

5. [ ] [ ] **Remove nuts or bolts/washers.**

In the next step, check for evidence that the crank arm is worn out or was originally a poor fit to the spindle. After removing the nut or bolt/washer, a square hole in the crank arm should become visible (this is where the spindle is inserted). If the end of the square portion of the spindle is recessed inside the square hole of the crank arm by any amount, then the fit is most likely acceptable. If the square end of the spindle fills up the entire depth of the square hole in the crank arm, then the fit is unacceptable. In this latter case, the nut or bolt that secures the crank arm will be stopped by the end of the spindle before it has pushed the crank arm far enough on to secure it. The resulting symptoms would be creaking sounds and repetitive loosening of the arm.

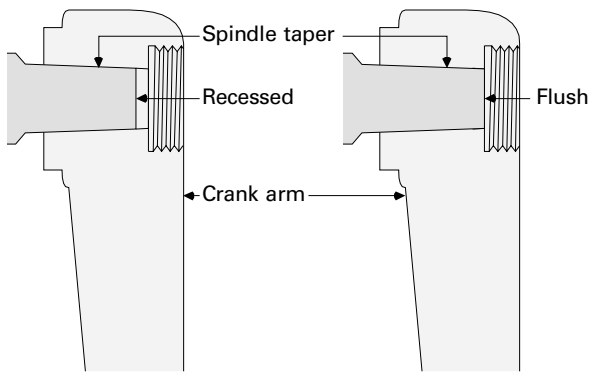

**20.3** The left picture shows the position of the spindle when fit is good and the right one shows when fit is bad, because the square portion of the spindle fills the full depth of the square hole in the crank arm.

- 6. After removing bolts/washers, inspect if spindle fills square hole (should not). Circle one choice for each arm removed:**
- Right arm OK?     not OK? (circle one).  
*If not OK, arm should be replaced.*
  - Left arm OK?     not OK? (circle one).  
*If not OK, arm should be replaced.*

### CRANK-ARM REMOVAL AND INSPECTION

In the following steps, a crank-arm extractor is installed and a crank arm removed. This is a very critical procedure. If done improperly, the crank arm or the spindle can be destroyed. Use the tool list (page 20-4) to select an appropriate extractor. It is critical that the extractor is compatible with the thread of the crank arm and with the shape of the end of the spindle. If using one of the recommended tools, simply follow the guidelines indicated in the table.

If using an existing extractor and it is not one of the models listed in the table, consider these factors. Thread compatibility is not an issue unless the crank arms are one of the following brands/models: T.A. (all models), Stronglight (models retained by a 16mm bolt only), Viscount (all models), Lambert (all models), or Campagnolo (all models since 1990). Viscount and Lambert removers are no longer available. For removers that are a compatible-thread type for the other brands, see the preceding tool list (page 20-4). All other cranks have the common 22×1mm thread. The other important factor is whether the spindle is a nut-type or bolt-type. Many different brands of extractors are compatible with each of these spindle types. If the tip of the extractor shaft is approximately 12mm diam-

eter, it is designed for use with spindles that accept a bolt to retain the crank arm. If the tip of the extractor shaft is approximately 10mm diameter, it is designed for use with spindles that accept a nut to retain the crank arm. *Use of the wrong extractor type may destroy the crank arm or the spindle!* The Park CCP-2 and CWP-5 are the *only* commonly available tools that are compatible with both spindle types.

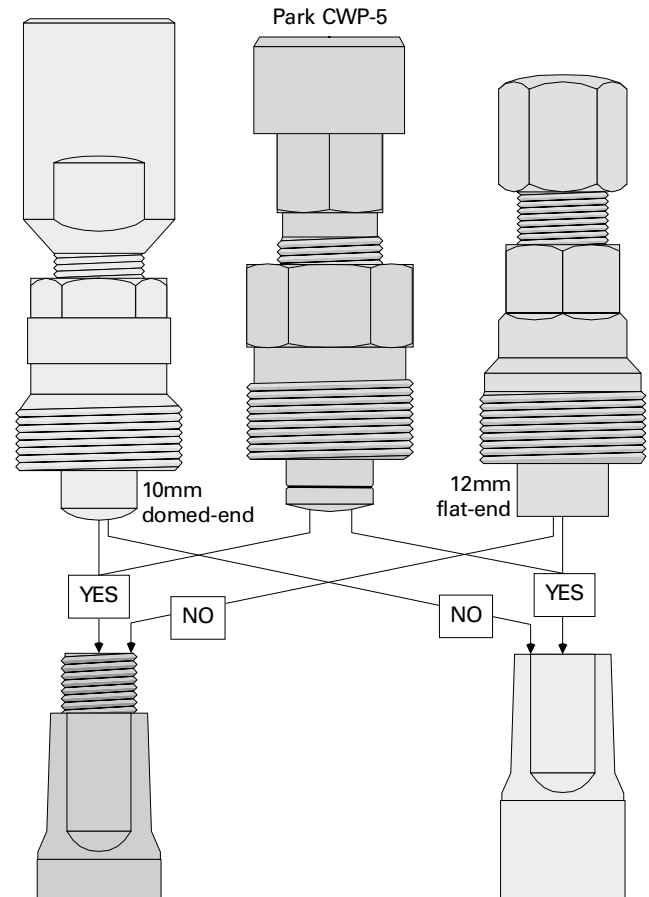

**20.4** This picture shows the two types of spindle ends with the corresponding correct remover to use. Note that the extractor used with a spindle that has a threaded stud on the end has a domed and relatively narrow tip. Note that the extractor used with a spindle that has no threaded stud on the end is flat on the end and has a relatively fat tip.

When threading the extractor into the crank arm, it should go in easily using just fingers. If the extractor does not thread in easily, it may be cross-threading, or the threads may be damaged. To avoid cross-threading, align the shaft of the extractor in line with the spindle axis rather than perpendicular to the face of the crank arm. If the threads are damaged, move ahead to the section of this chapter titled **REMOVING CRANK ARMS WITH DAMAGED EXTRACTOR THREADS** (page 20-13).

## 20 – TAPER-FIT CRANK ARMS

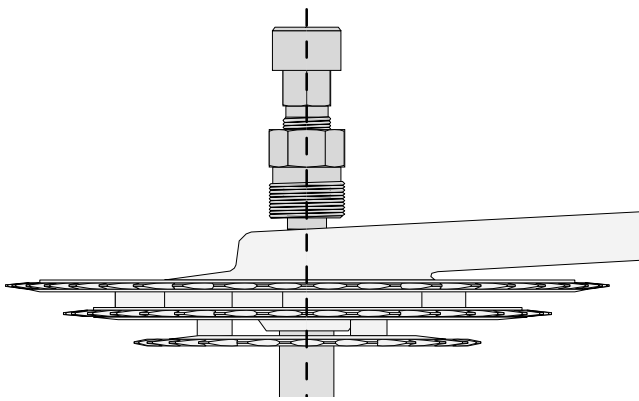

20.5 The drawing shows that a properly installed extractor must be in line with the spindle axis, but not necessarily perpendicular to the face of the crank arm.

In step #7, the extractor is secured in the arm with a wrench. There is no particular torque, and a lot of force is not required. The purpose is simply to ensure that the extractor is fully installed instead of just hanging up on a rough thread. If it is installed fully and it begins to rotate further during arm removal, stop the procedure before unrecoverable damage occurs.

### 7. [ ] [ ] Thread extractor into crank arm with fingers and snug with wrench.

A common mistake is to fail to install the extractor all the way in because the extractor shaft bottoms against the spindle before the extractor is fully threaded into the crank arm. Step #8 is a safety check so that this does not happen. If everything is set up right when the extractor body is secured with a wrench, it should still be possible to turn the extractor shaft either way with fingers. If the extractor shaft cannot be turned with fingers, the shaft is engaging the spindle before the extractor body is fully engaged in the crank-arm threads. When there is poor thread engagement, crank-arm-thread failure is likely to occur.

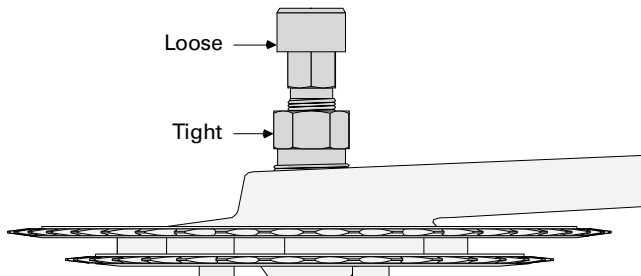

20.6 When the extractor is properly installed and when ready to remove the arm, the extractor body should be tight and the shaft should be loose and easily turned with fingers.

8. Check with fingers whether extractor shaft turns and check one of following choices:  
 [ ] [ ] Shaft is tight, loosen it further and re-snug extractor into crank.  
 [ ] [ ] Shaft is loose, ready for arm removal.

In step #9, tighten the extractor shaft to remove the crank arm. At this point in the procedure, there is still a possibility of removal failure and damage to the crank arm. If the correct warning signs are looked for during arm removal, it may be possible to detect a failure before the damage gets critical, solve the cause of the problem, and then successfully remove the arm. While tightening the extractor shaft, simultaneously watch for either of the following warning signs. *First, if the extractor body starts to rotate, the crank-arm extractor-threads may be stripping.* *Second, if the extractor appears to begin pulling out of the arm (or start cocking to one side in the arm), the crank-arm extractor-threads may be pulling out.* In both cases, immediately stop tightening the extractor shaft and remove the extractor from the arm. Inspect for a nut, bolt, or washer that was not removed. Inspect thread compatibility of the extractor to the crank arm, and inspect for compatibility of the extractor type with the spindle type. If no problems are found, then the only problem might be that the arm is seized to the spindle. Flood the hole with penetrating oil and attempt removal again.

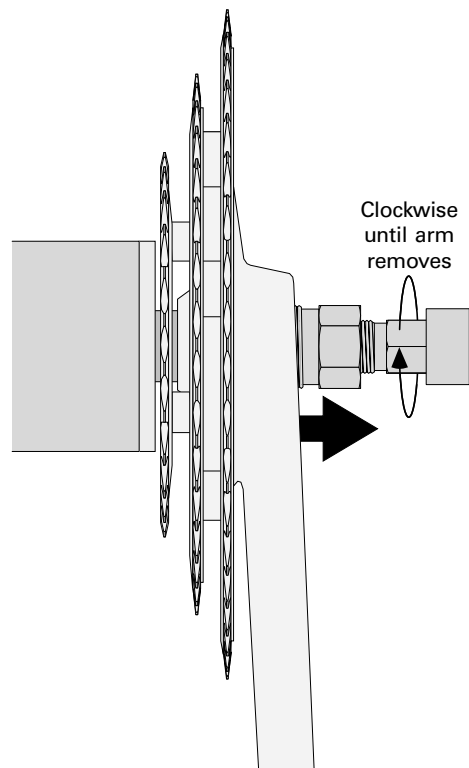

20.7 Turn the extractor shaft clockwise with a wrench to remove the crank arm.

9. [ ] [ ] Tighten extractor shaft to remove crank arm(s).  
 10. [ ] [ ] With arm still on spindle but loose, break loose extractor from crank arm.

After removing the crank arm, inspect for another indication of poor fit between the spindle and the crank arm. Crank arms invariably leave marks on spindle flats. As long as these marks do not extend all the way to the inner end of the flats, the crank-arm fit is acceptable. If the marks cover the full length of the spindle flats, the arm is worn out or has always had a bad fit to the spindle. If the crank arm presses all the way onto the spindle, then the arm is bottoming against the flat part of the spindle at the end of the flats, instead of the taper firmly wedging inside the square hole of the arm. This will result in creaking and ultimately in repetitive loosening of the crank arm.

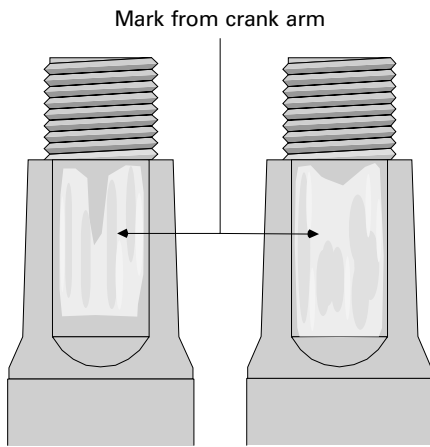

**20.8** The marks on the left spindle indicate good fit because they do not cover the full length of the spindle flat. The marks on the right spindle indicate poor fit because they cover the full length of the spindle flat.

11. Inspect marks on spindle flats and circle one choice for each arm removed:
  - Right arm OK? not OK? (circle one).  
*If not OK, arm should be replaced.*
  - Left arm OK? not OK? (circle one).  
*If not OK, arm should be replaced.*

### IF REPLACING RIGHT ARM OR TO FACILITATE CLEANING

12.  Remove chainrings (optional). See **CHAINRING REMOVAL, INSTALLATION, AND ALIGNMENT** procedure if removing or replacing chainrings.

### CRANK-ARM CLEANING AND DAMAGE INSPECTION

13.  Clean crank arms and chainrings (if any).  
In step #14, inspect inside the square hole in the crank arm for damage. A normal hole will have four flat sides, and maybe a burr on each flat where the

end of the spindle flat stopped. When an arm is ridden while it is loose, the spindle rotates slightly inside the hole of the arm. This will show up as extra corners on the edge of the hole. (See the following illustration for clarification.) Once this happens, the arm has a tendency to loosen up rapidly after proper installation. The best solution is to replace the arm. A temporary repair using Loctite RC680 (bearing supply houses) on the mating surfaces of the spindle and arm may be attempted, if the damage is not severe. Be aware that each time the damaged arm is removed and re-installed a fresh application of RC680 is required.

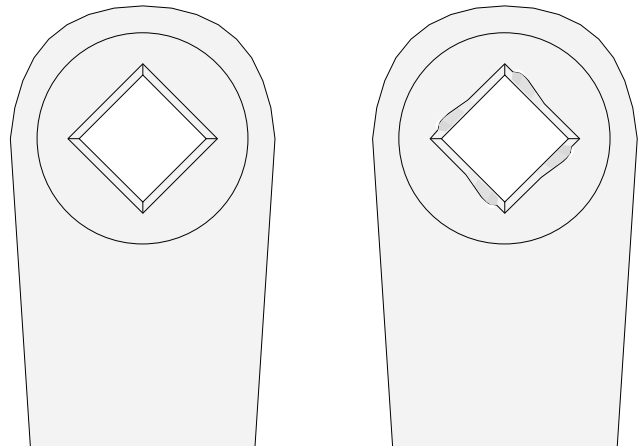

**20.9** Compare the hole in the left crank arm (good) to the hole in the right crank arm (damaged).

14. Inspect inside square hole in each crank arm for deformed flats and circle one choice for each arm removed:
  - Right arm OK? not OK? (circle one).  
*If not OK, arm should be replaced.*
  - Left arm OK? not OK? (circle one).  
*If not OK, arm should be replaced.*
15. Inspect arm for cracks originating at square hole in each crank arm and circle one choice for each arm removed:
  - Right arm OK? not OK? (circle one).  
*If not OK, arm should be replaced.*
  - Left arm OK? not OK? (circle one).  
*If not OK, arm should be replaced.*
16. Inspect for cracks originating at pedal-mounting hole in each crank arm and circle one choice for each arm removed:
  - Right arm OK? not OK? (circle one).  
*If not OK, arm should be replaced.*
  - Left arm OK? not OK? (circle one).  
*If not OK, arm should be replaced.*
17.  Inspect right arm (if removed) for cracks at crotch of spider arms to crank arm.  
OK? not OK? (circle one).  
*If not OK, arm should be replaced.*

## 20 – TAPER-FIT CRANK ARMS

### CRANK-ARM INSTALLATION

18. [ ] Install chainrings, if removed. See **CHAINRING REMOVAL, INSTALLATION, AND ALIGNMENT** procedure (page 23-10).

**NOTE:** If re-installing a single arm that was removed, skip to step 33.

In steps #19 through #31, install a right arm in all four possible positions in order to determine the position that results in the least chainring wobble. There is imprecision in both the fabrication of the spindle flats and in the fabrication of the square hole in the crank arm. In some combinations, the imprecision of each will add together to cause the chainrings to wobble unacceptably. In other combinations, the imprecision of each will cancel the other out, allowing the chainrings to run relatively true. This is why it is best to try mounting the crank arm in all four positions.

The above-mentioned technique requires that the arm be somewhat secured on the spindle. Of course, this could be done by securing the arm with the nut/bolt, checking the chainring wobble, removing the nut/bolt, and then using the extractor to remove the arm so that another position could be checked. This method is good, but time consuming. The method described in the following steps uses a soft hammer to strike the arm on and off, which will save considerable time and effort. If done properly, it is effective and will not damage any equipment. If unwilling to strike the crank arm with a soft hammer, then use normal mounting and removal procedures wherever the step suggests using a hammer.

#### **Installing a pair of crank arms**

19. [ ] Use a marker to mark one corner between two flats on right end of spindle.

20. [ ] Turn spindle so that mark is at 12:00.

21. [ ] Place right crank arm on spindle so that arm points to 6:00 and tap firmly on with rubber/plastic mallet.

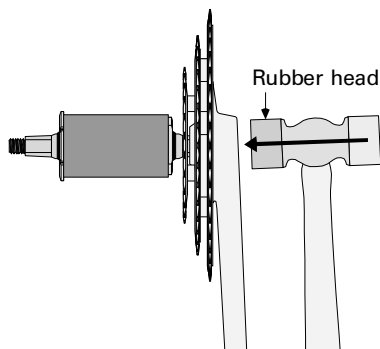

20.10 Strike the crank arm with a rubber/plastic mallet to temporarily secure the arm to the spindle. Pull on the arm to check that it does not jiggle or come off.

In step #22 and some later steps, spin the crank and check chainring wobble. If the front derailleur is still mounted and the cable hooked up, the best way to check chainring wobble is to position the nose of the derailleur's outer plate directly over the outer chainring. Sight down through the outer plate of the derailleur while spinning the crank and observe to what degree the chainring moves inside and outside of the nose of the derailleur's outer plate.

If the front derailleur is not set up, use another method to check wobble. Brace a hand against a frame tube and position the tip of a finger lightly against the inside face of the teeth of the outer chainring. As the rings spin, see and feel the teeth move towards and away from the finger.

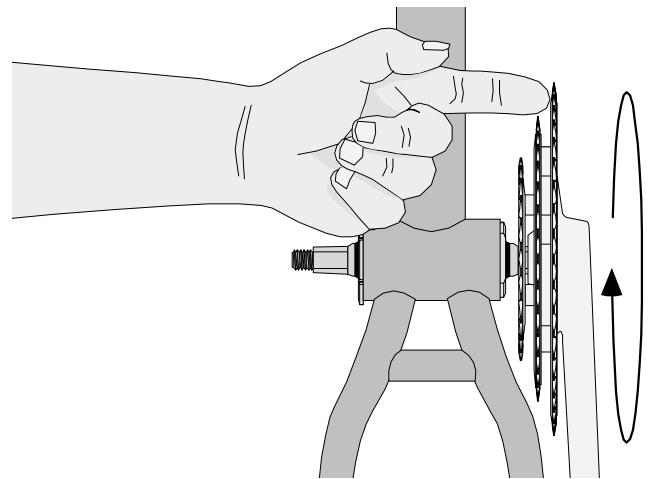

20.11 Use the tip of a finger against the inner face of the outer chainring teeth. As the chainrings spin, check the degree of wobble.

22. [ ] Check that crank arm is not loose on spindle and spin crank to check degree of chainring wobble.

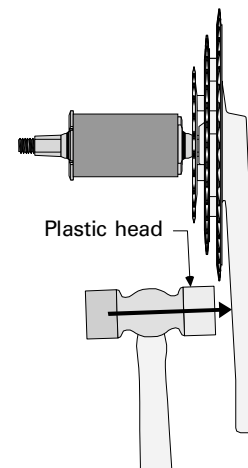

20.12 Tap on the back of the crank arm with the rubber/plastic mallet to remove the crank arm in order to check chainring wobble in another of the four possible mounting positions of the right crank arm.

23. [ ] Tap on back of crank arm with rubber/plastic mallet to remove arm.
24. [ ] Rotate spindle so that mark is at 3:00, and place right crank arm on spindle so that arm points to 6:00. Tap firmly on with rubber/plastic mallet.
25. Check that crank arm is not loose on spindle, and spin crank to check degree of chainring wobble. Check one of following choices:
  - [ ] *Better* than with spindle mark at 12:00.
  - [ ] *Not better* than with spindle mark at 12:00.
26. [ ] Tap on back of crank arm with rubber/plastic mallet to remove arm.
27. [ ] Rotate spindle so that mark is at 6:00, and place right crank arm on spindle so that arm points to 6:00. Tap firmly on with rubber/plastic mallet.
28. Check that crank arm is not loose on spindle, and spin crank to check degree of chainring wobble. Check one of following choices:
  - [ ] *Better* than with spindle mark at 12:00 or 3:00.
  - [ ] *Not better* than with spindle mark at 12:00 or 3:00.
29. [ ] Tap on back of crank arm with rubber/plastic mallet to remove arm.
30. [ ] Rotate spindle so that mark is at 9:00, and place right crank arm on spindle so that arm points to 6:00. Tap firmly on with rubber/plastic mallet.
31. Check that crank arm is not loose on spindle, and spin crank to check degree of chainring wobble. Check one of following choices:
  - [ ] *Better* than with spindle mark at 12:00, 3:00, or 6:00.
  - [ ] *Not better* than with spindle mark at 12:00, 3:00, or 6:00.
32. [ ] Tap on back of crank arm with rubber/plastic mallet to remove arm.

In step #33, prepare the arm for installation by cleaning the mating surfaces of the spindle and arm with acetone or alcohol. The purpose of this is to remove any traces of lubricant. Since these two pieces are held together by friction, grease or oil may enable the arm to go on further (not necessarily a good idea). Further is not more secure if arrived at by using lubrication. Crank manufacturers are unanimous in recommending against lubrication of the spindle when mounting the arm. Arguments to the contrary have been voiced, *but never lubricate the spindle flats!* If there is a concern about preventing corrosion or about contaminants getting in the gaps between the spindle flats and the hole flats in the arm, then treat the mating surfaces with Loctite 222 or 242 (bearing-supply or automotive-supply stores). The Loctite will seal the

surfaces from moisture or dirt, reduce creaking problems, will not cause the arms to be less secure, and will allow arm removal with normal effort.

33. [ ] [ ] Clean flats on spindle end(s) and in crank-arm square hole(s) with acetone or alcohol.

34. [ ] [ ] Grease bolt/nut threads (inside nuts) and under bolt head(s) or nut flange(s).

**NOTE:** Go to step 38 if one crank arm was removed and only one needs to be installed.

### ***Installing right arm***

35. [ ] Place right arm on spindle in same “better than” position as it was in highest numbered of steps 22, 25, 28, and 31.

36. Install nut, or bolt and washer (if any), and torque bolt/nut to one of following choices:

- [ ] Manufacturer’s maximum recommended torque (if literature for crank is available, and spindle and arm are brand-matched parts).

- [ ] Torque nut/bolt to 390in-lbs (32.5ft-lbs, or 65lbs@6" or 50lbs@8"), then check for ≥2mm clearance of chainrings to frame.

37. [ ] Grease dust-cap threads (if any) and install. Torque to 48in-lbs (16lbs@3") if dustcap is threaded.

### ***Installing second arm***

38. [ ] Place arm on spindle so that it points 180° away from already-installed arm.

39. Install nut, or bolt and washer (if any), and torque bolt/nut to one of following choices:

- [ ] Manufacturer’s maximum recommended torque (if literature for crank is available, and spindle and arm are brand-matched parts).

- [ ] Torque nut/bolt to 390in-lbs (32.5ft-lbs, or 65lbs@6" or 50lbs@8").

40. [ ] Grease dust-cap threads (if any) and install. Torque to 48in-lbs (16lbs@3") if dustcap is threaded.

## **CHECKING FIT OF REPLACEMENT CRANK ARM**

**NOTE:** Skip to step 53 if arms installed are original arms removed, not replacements.

### ***Checking chainring fit if replacement arm is a right arm***

If using old chainrings with a new crank arm, check the **CHAINRINGS** chapter (page 23-5) to determine whether the new arm is compatible with the chainrings. Chainring compatibility is not just a matter of whether the mounting holes in the chainrings and the crank arm match up. With some chainrings, spacing between the two is critical and not universal.

## 20 – TAPER-FIT CRANK ARMS

In the next step, measure the right chainring clearance. With the new arm installed, check the chainring position. Any change in clearance could represent a potential problem with shifting, chainline alignment, and frame clearance. Step #41 establishes whether the chainrings have changed position in a way that will cause a problem with frame clearances, and whether they have changed position enough to require adjustment of the front derailleur. Step #42 and #43 establish whether any chainline error has worsened or improved.

Some bikes have raised chain stays (chain stays that are above the chainrings and do not overlap the chainrings). In this case, clearance between the chainrings and the chain stays is no longer an issue. However, changes in chainring position still affect front-derailleur adjustment and chainline. With these bikes clearance to the chainstays cannot be measured, so the distance between the seat tube and the chainrings should be measured.

**41. Measure chainring-to-chainstay clearance and check one of following choices (measure clearance to seat tube if bike has raised chain stays):**

Clearance is  $\geq 2$ mm (ignore for bikes with raised chain stays), and clearance is  $> .2$ mm different than number in step 2.

*Front-derailleur limit screws and cable will need adjustment.*

Clearance is  $< 2$ mm, *replacement arm is unacceptable to use with existing spindle.* (Skip this step for bikes with raised chain stays.)

Clearance is different by  $\leq .2$ mm from number in step 2, *front-derailleur adjustment is not needed.* Arm is a good fit.

In the next two steps, measure the chainline after installing a new right crank arm to determine whether it has been changed enough to create or solve a problem. Don't limit your focus to whether there is a measurable error, but include whether the error has changed enough to *introduce or eliminate chainline error symptoms*. See **CHAINLINE** chapter for information about how to measure chainline error (page 27-6) and symptoms of chainline error (page 27-3).

**42. Measure chainline error, record here:**  
Chainrings *out (+)* or *in (-)* (circle one)?  
Amount: \_\_\_\_\_

**43. Compare step 42 to number and direction in step 3, then choose one of following choices:**

Error is equal to step 3. Arm is acceptable if no chainline-error symptoms were experienced with original arm.

Error is in the same direction but less than step 3. Arm is acceptable unless previous chainline error was unacceptable and change is not enough to eliminate symptoms. Bike should be evaluated for chainline-error symptoms.

Error is in new direction. Bike should be evaluated for chainline-error symptoms.

Error is in same direction but greater. Bike should be evaluated for chainline-error symptoms.

### **Checking fit to spindle of either or both arms**

**NOTE:** Perform steps 44–52 complete for one arm before doing 44–52 for a second arm.

When installing mismatched brands of arm and spindle, or installing a used arm on a different spindle, it is important to check whether the arm and spindle are a compatible fit. The only practical way to check this is to remove the arms again and inspect the conditions found during and after removal. If everything is fine, then just reinstall the arms. To avoid having to re-find the best of four positions for the right arm, do not remove both arms at once.

44.    Remove dust cap(s) (if any).

45.    Remove nuts or bolts/washers.

46. Inspect crank-arm fit (does spindle fill square hole?) after removing bolts/washers and circle one choice for each arm removed:

Right arm OK? not OK? (circle one).  
*If not OK, arm should be replaced.*

Left arm OK? not OK? (circle one).  
*If not OK, arm should be replaced.*

47.    Thread extractor into crank-arm fit with fingers and snug with wrench.

48. Check with fingers whether extractor shaft turns and check one of following choices:

Shaft is tight, loosen it further and re-snug extractor into crank.

Shaft is loose, ready for arm removal.

49.    Tighten extractor shaft to remove crank arm(s).

50.    With arm still on spindle (but loose), break loose extractor from crank arm.

51. Inspect marks on spindle flats and circle one choice for each arm removed:

Right arm OK? not OK? (circle one).  
*If not OK, arm should be replaced.*

Left arm OK? not OK? (circle one).  
*If not OK, arm should be replaced.*

52.    Repeat steps 38 through 40 for each arm removed.

## INSTALL PEDALS

53.   Install pedal(s) if removed. See **PEDAL REMOVAL AND INSTALLATION** procedure.

## REMOVING CRANK ARMS WITH DAMAGED EXTRACTOR THREADS

### MANGLED THREADS

With luck, the only problem being experienced is getting the extractor to start threading into the crank arm without jamming. If this is the case, there is a simple repair. The tool needed is a Bicycle Research TC-8 crank-arm-thread chaser. This simple tool has a pilot shaft that attaches to the spindle once the nut/bolt is removed. A thread chaser slips over the pilot and then threads into the crank arm, re-aligning the mangled threads. Removal of the crank arm is then done normally after removing the TC-8.

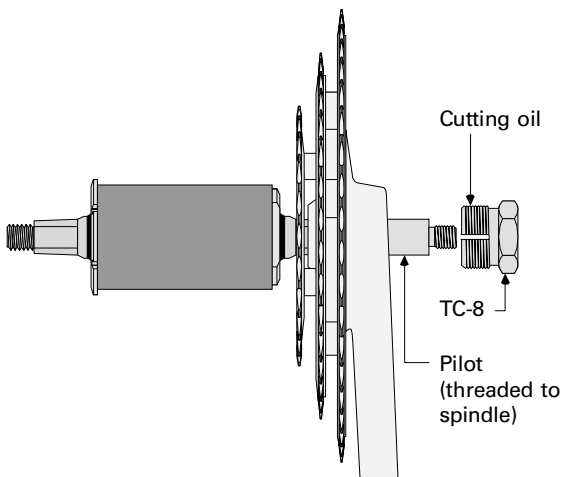

20.13 After attaching the pilot shaft to the spindle, thread the chaser part of the TC-8 into the crank arm to re-align the threads.

1. [ ] Attach pilot shaft to spindle.
2. [ ] Lubricate threads of thread chaser with aluminum cutting oil or other very light oil.
3. [ ] Slip chaser onto pilot shaft and thread chaser into crank arm. Resistance may be encountered and force may be necessary to thread chaser in fully.
4. [ ] Remove thread chaser and pilot and attempt normal removal of crank arm. If threads fail, proceed to **STRIPPED THREADS**.

### STRIPPED THREADS

Stripped threads are clearly identified when the extractor pulls out of the arm, instead of the arm pulling off of the spindle when attempting arm removal. In this case, count on needing a new arm. The prob-

lem is how to get the arm off in order to replace it. The following steps actually include two methods for arm removal. If at the end of step #3 the arm has loosened adequately, then no more is needed. If not, continue to the end of the steps.

Many modern right arms are shaped in such a way that there is no flat surface to strike with the hammer. (See figure 20.14.) Since the arm should be considered a loss already, the solution to this is not as drastic as it sounds. Remove the chainrings and use a hacksaw to cut off the chainring-mounting arm that is just past the chainring-mounting arm that is immediately adjacent to the crank arm. This should create the spot needed to strike with the hammer.

1. [ ] Reinstall any arm or pedals that have been removed, and put bike in rideable condition.
2. [ ] Install nut/bolt onto spindle on side with stripped extractor threads in arm, then loosen nut/bolt 2–3 full turns.
3. [ ] In an untrafficked parking lot or up a steep hill, ride bike hard. (Use brakes to create resistance in flat parking lots.) Crank arm should loosen noticeably. If not, proceed to next step.
4. [ ] Back in shop, remove nut/bolt fully.

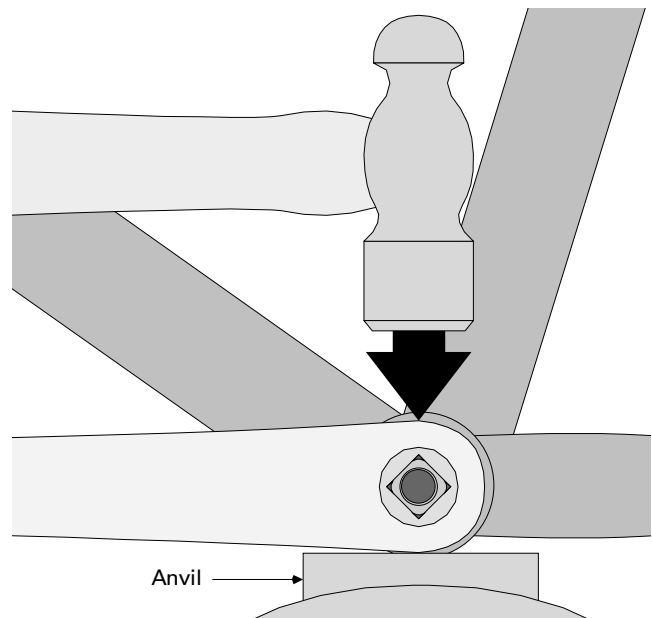

20.14 With the nut/bolt removed and the arm supported on an anvil or similar surface, strike hard and repeatedly with a ball peen hammer to get the arm to pop off.

5. [ ] With crank arm horizontal, support crank arm under the end that spindle is inserted in on anvil or some other firm support.
6. [ ] Strike top side of arm with a ball peen hammer as hard as possible with control. Strike repeatedly until crank arm pops off of spindle. (Arm is not re-useable.)

## ***CRANK-ARM TROUBLESHOOTING***

<b><i>Cause</i></b>	<b><i>Solution</i></b>
<b>SYMPTOM:</b> <i>When riding, one ankle feels as though the end of the pedal is rocking up and down, and/or it feels as though the surface of the pedal is rotating back and forth.</i>	
Pedal shaft is bent from a crash.	Remove pedal and inspect end of pedal shaft for oscillation when rotating. Replace if bad. If symptom persists when pedal shaft is good, crank arm is bent and should be replaced.
If pedal shaft is not bent, crank arm is bent.	Replace crank arm.
<b>SYMPTOM:</b> <i>A popping sound or sensation is experienced once per crank revolution, often on the down stroke of the right pedal.</i>	
Loose crank arm.	Check and secure crank arm.
Loose pedal-cage piece(s).	Check and secure pedal-cage piece(s).
Loose pedal mounting.	Check and secure pedal mounting.
Loose chainring bolt(s).	Check and secure chainring-mounting bolt(s).
Loose B.B. cup, lockring, or retaining ring.	Check and secure B.B. cups, lockrings, or retaining rings.
Bent chainring tooth.	Inspect and bend back.
<b>SYMPTOM:</b> <i>A ticking or scraping sound is heard once per crank revolution.</i>	
Loose crank arm causing chainring wobble, causing chain to scrape derailleur cage.	Check and secure crank arm.
Crank arm is hitting front-derailleur cage.	Re-adjust front-derailleur limit screws and/or rotational alignment.
<b>SYMPTOM:</b> <i>Chainrings, chainring-mounting bolts, or some other part of the crank-arm assembly is rubbing the chain stay continuously or intermittently when the crank is being spun when not under load.</i>	
Crank arms worn out or bad fit to spindle.	Perform removal process, including fit inspections.
Bottom bracket spindle is too short.	Replace spindle or cartridge bottom bracket with one that will position crank arm further out.
<b>SYMPTOM:</b> <i>Wear marks are found on the chain stay where they might have been left by the chainrings, chainring-mounting bolts, or some other part of the crank-arm assembly, but no rubbing is evident upon visual inspection.</i>	
Clearance that is adequate without load is not adequate when crank assembly and/or chain stays flex under load.	Check for and replace worn out or misfit crank arm. Replace spindle or cartridge bottom bracket with one that will position crank arm further out.
<b>SYMPTOM:</b> <i>Extractor mounting threads fail when crank-arm removal is attempted.</i>	
Extractor was not fully threaded into crank arm.	Attempt repair with Bicycle Research TC-8 thread chaser. If threads fail completely when attempting removal again, use procedure for removing crank arms with damaged extractor-mounting threads. Replace crank arm.
Crank-arm removal was attempted without removal of the retaining nut or bolt, or without removal of the washer that was under the bolt head.	Attempt repair with Bicycle Research TC-8 thread chaser. If threads fail completely when attempting removal again, use procedure for removing crank arms with damaged extractor-mounting threads. Replace crank arm.
Crank arm was mounted excessively tight.	Use procedure for removing crank arms with damaged extractor-mounting threads. Replace crank arm.

<b><i>Cause</i></b>	<b><i>Solution</i></b>
<b>SYMPTOM:</b> <i>A creaking sound is coming from the crank, particularly under hard pedaling load.</i>	
Crank arm is loosening.	Check and secure crank arm.
Mating surfaces of crank arm and spindle are contaminated.	Remove and clean mating surfaces. Optional: add Loctite #242 or #222 to mating surfaces to fill gaps.
Crank arm is a poor fit to spindle due to incompatibility or wear.	Remove and inspect crank arm and spindle for evidence of poor fit. Replace if there is evidence that fit is bad.
Loose pedal-cage piece(s).	Check and secure pedal-cage piece(s).
Loose pedal mounting.	Check and secure pedal mounting.
Loose chainring bolt(s).	Check and secure chainring-mounting bolt(s).
Cracks in crank arm or chainring-mounting arms.	Remove, clean, and inspect crank arm and chainring-mounting arms.
Loose B.B. cup, lockring, or retaining ring.	Check and secure B.B. cups, lockrings, or retaining rings.
<b>SYMPTOM:</b> <i>A crank arm is repeatedly loosening up.</i>	
Inadequate torque.	Use torque wrench if not already. Use maximum recommended torque, if not already.
Crank arm is worn out and fits poorly, or is not compatible with spindle and fits poorly.	Remove and inspect crank arm and spindle for evidence of poor fit.
Crank-arm and spindle-mating surfaces are contaminated with lubricant.	Clean mating surfaces and remount dry or with Loctite #242 or #222.

# SHIMANO SPLINE-FIT CRANK ARMS

## TERMINOLOGY

**Splines:** An alternating arrangement of axially-aligned lands (ridges) and flutes (grooves) around a cylinder.

**Splined spindle:** A bottom-bracket spindle that is splined on the ends, as opposed to the traditional squared taper.

**Splined hole:** A cylindrical hole that is splined.

**One-Key Release:** A design of crank-arm retaining bolt that serves as a remover when the bolt is loosened.

## TYPES

There are two types of spline patterns used. The original pattern, found on Shimano XTR, Dura-Ace, Ultegra, and 105 crank arms and corresponding bottom brackets are the “short-spline” type. The critical spline dimensions of this type are that the eight lands (ridges) are 2.2mm thick and 5mm long. The second pattern, introduced on 2000 Deore XT and LX models and corresponding bottom brackets, are the “long-spline” type. This type has eight lands that are each 2.8mm thick and 9mm long and is not interchangeable with the 2.2 × 5mm pattern. After seeing both, it is effortless to visually distinguish the types from each other by the relative length of the splines.

## CRANK-ARM REMOVAL

Some of the models feature Shimano One-Key Release. This feature can easily be identified by looking at the cap that surrounds the Allen bolt that secures the crank. If the cap has two pin holes 180° apart, then the mechanism is a One-Key Release. In this case, to remove the crank arm, first make sure that the cap is secure with a pin spanner, then loosen the Allen bolt, which automatically removes the arm. If the cap tends to unthread while loosening the bolt, remove the cap, check that the plastic washer is between the cap and bolt head, grease the back side of the cap, then reinstall the cap and try again. If the One-Key Release fails or is missing parts, remove the bolt and use the technique described next for cranks with no One-Key Release.

Certain models of spline-fit crank arms do not have a One-Key Release, and cannot be removed by a conventional remover without the use on an additional

tool. That additional tool is a Shimano TL-FC15, which is a plug that goes in the spindle after the removal of the crank-arm mounting bolt. Only with this plug in place is it possible to use a regular crank-arm remover, because otherwise the shaft of the extractor would insert inside the oversize hole in the spindle and therefore not press against the end of the spindle.

## CRANK-ARM INSTALLATION

If replacing parts or assembling parts that have never previously been installed, make sure the spline pattern of the spindle and the crank arms are compatible. Since the splined hole of the crank arm is partially filled by the mounting bolt, it is difficult to take any measurements of the spline pattern. Check whether the spindle splines are 5mm or 9mm long. As of the 2000 model year, if the spindle splines are 9mm long, then the only compatible arms are marked XT and LX. According to Shimano, the longer spline pattern is required by the softer metals used in the less expensive models, so in subsequent years expect this spline pattern on more basic models only.

The following arm-installation procedure includes removal of the One-Key Release, which insures that the splines will engage properly. Leaving the One-Key Release in the arm while installing the arm risks improper engagement of the splines. Furthermore, the proper setup of the One-Key Release is critical to its function when removing the arm, and it is likely it is not installed correctly. If not removing the One-Key Release because there is no question that it is properly installed, take every caution to insure that the splines are engaging properly when securing the arm.

If the arm being installed does not utilize the One-Key Release, simply perform steps 1–6.

1. [ ] Grease spindle splines and cylindrical taper.
2. [ ] If installed, remove One-Key Release.
3. [ ] Place arm on spindle, checking that splines are engaged.
4. [ ] Grease metal washer and install in arm.
5. [ ] Grease bolt threads and thread into spindle.
6. [ ] Torque bolt to 435in-lbs.
7. [ ] Install plastic washer over bolt head.
8. [ ] Grease inside of One-Key Release cap.
9. [ ] Put one drop of Loctite 242 on One-Key Release cap threads.
10. [ ] Install and secure cap.